

PROJECTA

INTELLI-CHARGE

BATTERY CHARGER

12 VOLT, 7 STAGE SWITCHMODE



P/No.s IC700, IC1000, IC1500

WARNING

- Explosive gases may escape from the battery during charging. Prevent flames and sparks. Provide adequate ventilation.
- Before charging, read the instructions.
- For indoor use. Do not expose to rain.
- For charging 12 Volt lead acid batteries ONLY.
- Disconnect the 240V mains supply before making or breaking the connections to the battery.
- The battery charger must be plugged into an earthed socket-outlet.
- Connection to supply mains is to be in accordance with National wiring rules.
- Do not attempt to charge non-rechargeable batteries.
- Never charge a frozen battery.
- If the AC cord is damaged do not attempt to use. It must be replaced or repaired by a qualified person.
- Corrosive substances may escape from the battery during charging and damage delicate surfaces. Store and charge in a suitable area.
- Ensure all vehicle accessories including lights, heaters, appliances etc are turned off prior to charging.
- This appliance is not intended for use by young children or infirm persons unless they have been adequately supervised by a responsible person to ensure that they can use the appliance safely.
- Young children should be supervised to ensure that they do not play with the appliance.

FEATURES

7-STAGE AUTOMATIC CHARGING

This is a fully automatic battery charger with 7 charge stages.

Automatic charging protects your battery from being overcharged so you can leave the charger connected to the battery indefinitely.

7-stage charging is a very comprehensive and accurate charging technique that gives your battery longer life and better performance compared to using traditional chargers.

Projecta's *Intelli-Charge* chargers can be adjusted to suit a number of different battery types including GEL, AGM, WET and Calcium. The chargers can also help restore drained and sulphated batteries.

The 7 charge stages are:

Desulphation; Soft Start; Bulk; Absorption; Analysis; Recondition and Float.

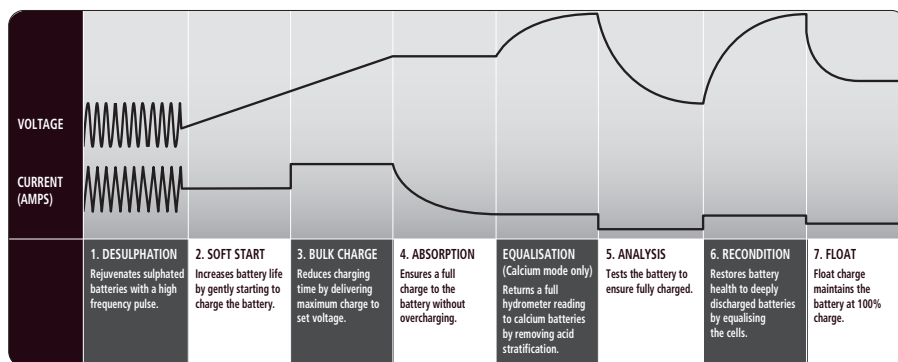

Desulphation

The Desulphation stage is designed to break down sulphation occurring in batteries that have been left flat for extended periods of time, returning them back to full charge.

Sulphation occurs when lead-sulphate hardens and clogs up the battery cells.

Soft Start

This is a preliminary charge process that gently introduces power to the battery, protecting the battery and increasing battery life.

Bulk (Constant Current)

The Bulk stage reduces charging time by charging the battery at the maximum rate (constant current) to a set voltage, at which point the battery is approximately 80% charged.

Absorption (Constant Voltage)

The absorption stage charges the battery to 100% by adjusting the charge rate allowing the battery to absorb more power.

Equalisation (Calcium mode only)

Designed especially for calcium batteries, this stage returns calcium batteries to full service by removing acid stratification of the electrolyte.

Analysis

The analysis mode tests the battery to ensure that it has taken the charge; if the battery passes the test the charger will proceed to the float stage, but if the battery fails the test, the charger will apply a recondition charge to try to return the battery to full charge.

Recondition

If after charging, the battery is unable to hold the charge the battery reconditioning function is initiated automatically. This is most likely to take place on batteries that have been deeply discharged, prior to charging. The Recondition mode will then run for 4 hours and at the end will retest the battery. The *Intelli-Charge* battery charger will perform the recondition charge up to 3 times before switching the charging cycle to Float with an error indication.

Float

The Float stage maintains the battery at 100% charge without overcharging or damaging the battery. This means the charger can be left connected to the battery indefinitely.

MULTI CHEMISTRY

The Multi-Chem function allows you to set the charging profile to suit each battery's chemistry type (GEL, AGM, WET and Calcium). This ensures correct and thorough charging and maximises battery performance and battery life.

POWER SUPPLY

When Power Supply mode is selected, you can safely run an appliance or load from your battery. An appliance can also be run directly from the battery clamps if required, for example using the charger as a memory saver when disconnecting the battery from the vehicle.

CHARGE STATUS INDICATOR

The CHARGING and FULLY CHARGED LEDs will illuminate and flash in various patterns to indicate the different stages of charging. See below for flash patterns.

	Desulphation	Soft Start	Bulk	Absorption/ Equalisation	Analyse	Recondition	Float
Red LED ● Power							
Blue LED ● Charging	----- (Fast Flash)	- - - - - (Slow Flash)	—————	—————		- - - - -	
Green LED ● Full				- - - - -	- - - - -	- - - - -	—————

CHARGING LED: blue LED illuminates and flashes during charging process.

FULLY CHARGED LED: green LED illuminates (solid) when fully charged.

POLARITY PROTECTION

Prevents the output leads from sparking due to accidental reverse connection or short circuit making the charger safer to use around batteries.

OVER TEMPERATURE PROTECTION

If the temperature within the charger rises too high, the charger will begin to cool down by turning on the fan, and if the temperature continues to rise it will begin reducing the power output. If still unsuccessful, the charger will shutdown until it cools down.

SWITCHMODE TECHNOLOGY

Using the latest technology in battery chargers, switchmode chargers convert 240VAC power to 12VDC power using electronic components unlike traditional battery chargers that rely on heavy transformers. This allows the charger to be lightweight and compact without sacrificing on performance.

COOLING FAN

The charger is fitted with a thermostatically controlled fan to cool onboard electronics and maintain charging performance. The cooling fan will engage automatically when there is a high load on the battery or there is sufficient heat build up.

SPECIFICATIONS

P/No.	IC700	IC1000	IC1500
Type	7 stage	7 stage	7 stage
Input (Nominal)	240VAC, 50Hz	240VAC, 50Hz	240VAC, 50Hz
Input Power	216W	288W	408W
Output Voltage	12V	12V	12V
Output Current	7A	10A	15A
Minimum Start Voltage	2.5V	2.5V	2.5V
Back Drain	1mA	1mA	1mA
CHARGE CONTROL			
Desulphation	High Frequency Pulse charge up to 11V		
Soft Start	3.5A up to 12V	5.0A up to 12V	7.5A up to 12V
Bulk	7A up to: 14.1V (GEL) 14.4V (AGM) 14.7V (WET) 14.7V (CALCIUM)	10A up to: 14.1V (GEL) 14.4V (AGM) 14.7V (WET) 14.7V (CALCIUM)	15A up to: 14.1V (GEL) 14.4V (AGM) 14.7V (WET) 14.7V (CALCIUM)
Absorption	Constant voltage until current drops to 1.05A	Constant voltage until current drops to 1.5A	Constant voltage until current drops to 2.25A
Equalization (Calcium mode only)	Constant current (2.0A) up to 16V then hold for 1 hour or 12 hour timeout	Constant current (2.0A) up to 16V then hold for 1 hour or 12 hour timeout	Constant current (2.2A) up to 16V then hold for 1 hour or 12 hour timeout
Analysis	Monitors battery for 90 sec		
Recondition	Constant current (1.05A) for 4 hours limited to: 14.1V (GEL) 14.4V (AGM) 16V (WET) 16V (CALCIUM)	Constant current (1.5A) for 4 hours limited to: 14.1V (GEL) 14.4V (AGM) 16V (WET) 16V (CALCIUM)	Constant current (2.25A) for 4 hours limited to: 14.1V (GEL) 14.4V (AGM) 16V (WET) 16V (CALCIUM)
Float	13.7V	13.7V	13.7V
POWER SUPPLY			
Set Voltage	13.8VDC	13.8VDC	13.8VDC
Maximum Current	7A	10A	15A
BATTERY RANGE			
Deep Cycle	50–140Ah	70–200Ah	85–300Ah
Automotive	300–800CCA	450–1000CCA	465–2000CCA
Marine	350–900MCA	500–1200MCA	600–2500MCA
Types of Batteries	Most types of lead acid batteries including GEL, AGM, WET CELL and CALCIUM		
Size (mm)	182 x 61 x 108	202 x 61 x 108	222 x 61 x 108
Weight	0.95 Kg	1.15Kg	1.25Kg

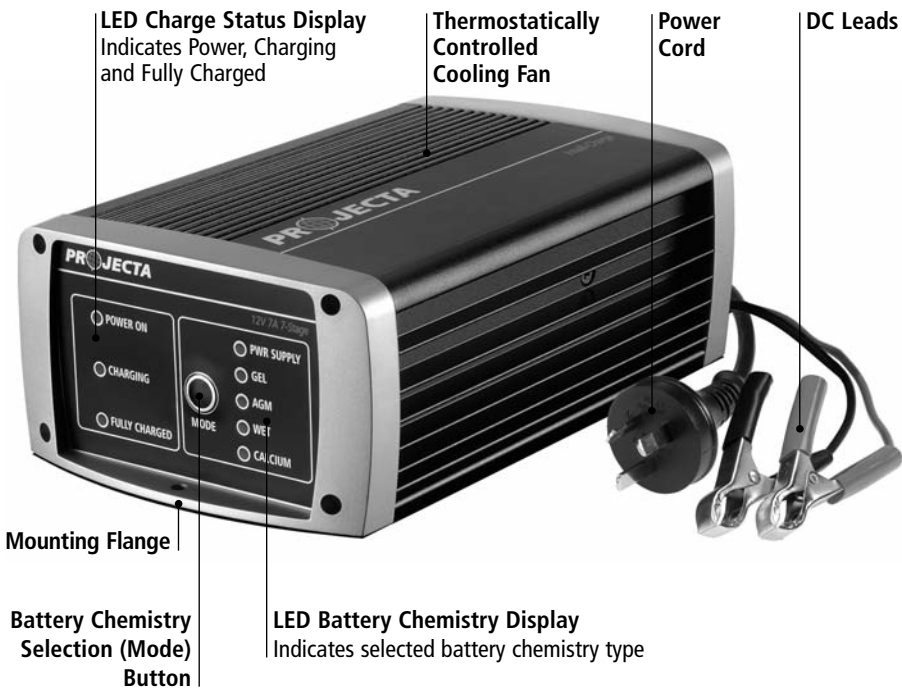

IC700

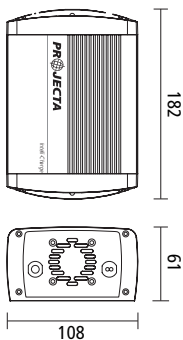

IC1000

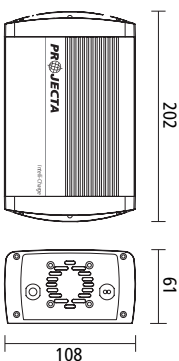

IC1500

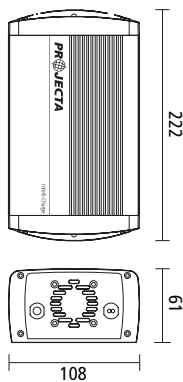

CHARGING INSTRUCTIONS

STEP 1 – CHECK THE ELECTROLYTE LEVEL

Prior to charging the battery, remove the vent caps and check the electrolyte level (not required on sealed & maintenance free batteries). The electrolyte should be 6mm (1/4") above the battery's plates. If low, top up with distilled water to the correct level and refit the vent caps.

STEP 2A – CONNECTION OUT OF THE VEHICLE

Connect the RED lead (battery clip) from the charger to the Positive (+) battery post.

Connect the BLACK lead (battery clip) from the charger to the Negative (-) battery post.

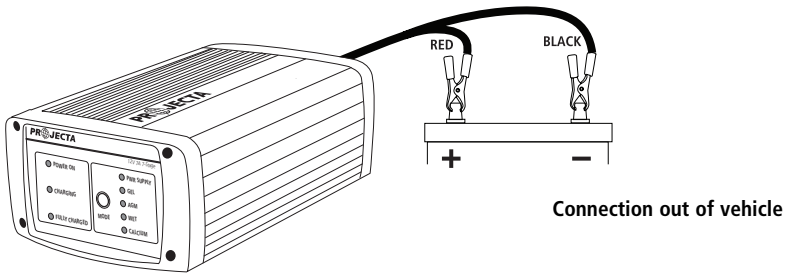

STEP 2B – CONNECTION IN VEHICLE

Determine if the vehicle is Positively (+) or Negatively (-) earthed. Negatively earthed vehicles have a cable (usually black) from the Negative battery terminal to the vehicle's chassis.

Negatively earthed (most vehicles)

Connect the RED lead (battery clip) from the charger to the Positive (+) battery terminal.

Connect the BLACK lead (battery clip) from the charger to the vehicle's chassis away from the fuel line or moving parts.

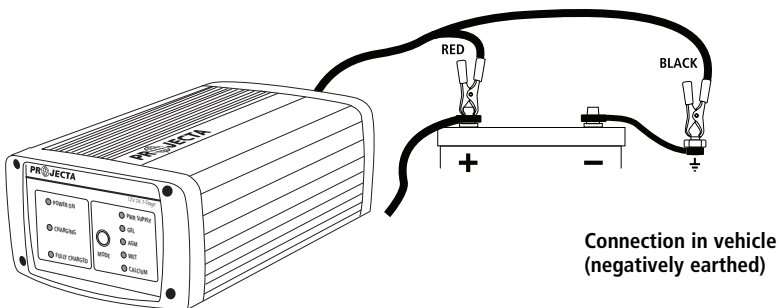

Positively earthed

Connect the BLACK lead (battery clip) from the charger to the Negative (-) battery terminal.

Connect the RED lead (battery clip) from the charger to the vehicle's chassis away from the fuel line or moving parts.

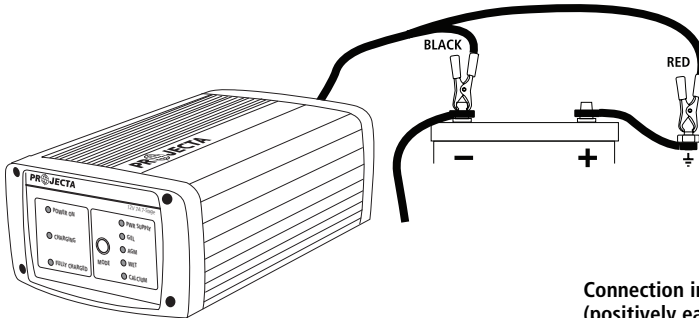

Connection in vehicle
(positively earthed)

STEP 3 – CONNECT TO 240V MAINS POWER

Connect the battery charger to the 240V mains powered socket and turn on the mains power.

STEP 4 – SET BATTERY CHEMISTRY TYPE

Battery Chemistry should be selected by the type of battery being charged (refer to the battery manufacturer's specifications for battery type). Refer to page 12 for a detailed explanation.

For example if you are charging an AGM battery, then AGM mode will need to be selected. This can be done by the following procedure:

- Press the Mode button; all the LEDs will come on. Wait for the LEDs to turn off.
- Press the Mode button repeatedly until the correct battery type is selected.

STEP 5 – CHARGING

During the charge process, the CHARGING and FULLY CHARGED LED will flash various patterns. This is normal and indicates the various charge stages. Refer to "How can I tell what stage the battery charger is in" in the FAQ section, page 14.

When the FULLY CHARGED LED remains on, this is known as the float stage and the charger can be left connected to the battery without over charging.

If the POWER LED is flashing, there is fault; refer to "Fault Codes" explanation on page 13 of this manual.

STEP 6 – DISCONNECTION

Ensure the 240V mains switch is turned off and the charger is disconnected from the 240V mains power.

Battery out of vehicle

Remove the BLACK lead (battery clip) from the battery.

Remove the RED lead (battery clip) from battery.

Battery in vehicle

Remove the chassis connection.

Remove the battery terminal connection.

STEP 7 – CHECK THE ELECTROLYTE LEVEL (CALCIUM MODE ONLY)

Check the electrolyte level and top up if required.

MOUNTING INSTRUCTIONS

Intelli-Charge chargers are designed for indoor, out of weather use only. Ensure that both charger and battery are in a well-ventilated space during charging.

The battery charger end plates include a mounting flange for easy mounting. If permanently fixed the charger should be mounted to a suitable horizontal or vertical panel, with at least 10cm clearance from the end plates to provide adequate ventilation for the cooling fan.

PERMANENT WIRING TO BATTERY

It is possible to hard wire the DC charging leads to the battery for permanent installations.

You will need 2 x ring terminals, an inline fuse holder and a fuse with a rating equal to or greater than twice the chargers output. (See below)

IC700 = 15 Amp fuse

IC1000 = 20 Amp fuse

IC1500 = 30 Amp fuse

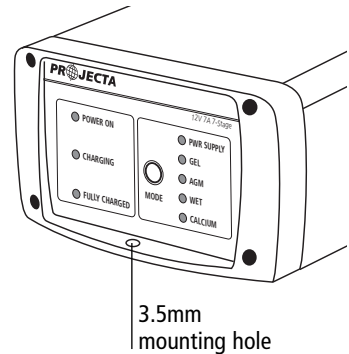

Connection:

1. Cut off the supplied battery clips; ensure you leave sufficient cable to reach the battery terminals. (DO NOT extend the battery charger DC cables, as the added voltage drop will cause incorrect charging).
2. Fit a ring terminal to the BLACK Negative (-) wire.
3. Connect the inline fuse to the RED Positive (+) wire.
4. Connect a ring terminal to the other end of the inline fuse.
5. Connect the RED lead (with inline fuse and ring terminal) to the Positive (+) battery post.
6. Connect the BLACK lead (with ring terminal) to the Negative (-) battery post.
7. Fit the correctly rated fuse.

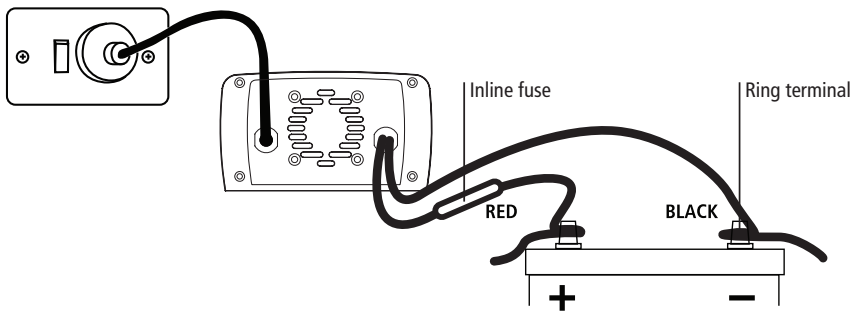

If the charger is used in a Permanent/Hard Wired application and the vehicle will not be used for some time, it is best to leave the charger connected to mains power (turned 'On') so that it can maintain the battery fully charged.

Ensure any modification to the 240V mains lead is carried out by a qualified person and that connection to supply mains is in accordance with National wiring rules.

BATTERY CHEMISTRY SELECTION

The Multi-Chem function allows you to set the charging profile to suit each battery's chemistry type (GEL, AGM, WET and Calcium). This ensures correct and thorough charging and maximizes battery performance and battery life.

1. Press the Mode button; all the lights will come on. Wait for the lights to turn off.
2. Press the Mode button repeatedly until the correct battery type is selected.

POWER SUPPLY (CONSTANT VOLTAGE OF 13.8 VOLTS)

This sets the charger in power supply mode giving a constant voltage of 13.8VDC. This mode is best used where appliances are drawing power from the battery, for example like a Fridge. Although the charger is designed to work with a battery connected, it can also work without a battery.

GEL (MAX VOLTAGE OF 14.1 VOLTS)

This charge mode is designed for GEL batteries and has a maximum charge voltage of 14.1V. Note that some GEL batteries require a higher charge voltage such as 14.4V. The AGM mode can be used if this is required.

AGM (MAX VOLTAGE OF 14.4 VOLTS)

This charge mode is designed for AGM batteries and has a maximum charge voltage of 14.4V.

WET (BULK AND ABSORPTION 14.7 VOLTS, RECONDITION UP TO 16 VOLTS)

This charge mode is designed for WET batteries and has a maximum charge voltage of 14.7V during Bulk and Absorption stages and 16.0V during the Recondition stage.

CALCIUM (BULK AND ABSORPTION 14.7 VOLTS, EQUALIZATION AND RECONDITION UP TO 16 VOLTS)

This charge mode is best suited for Calcium batteries that have been deeply discharged and require an equalization charge to restore a full electrolyte reading. If the battery requires a simple 'top-up', the WET charge mode can be used.

FAULT CODES

There are three error codes that may be displayed. These will be displayed in the following way:

Power (Red LED)	Charging (Blue LED)	Full (Green LED)	Fault	Remedy
— — — (Slow Flash)	OFF	OFF	Short circuit or reverse connection of the clips	Check clips are not touching each other OR Check the clips are correctly connected to the battery
— — — — — (Fast Flash)	OFF	OFF	Bulk charging has timed out and stopped after 22 hours	Battery may be faulty
— — — (Slow Flash)	OFF	ON	The charger has entered recondition mode 3 times and has timed out	Battery may be faulty and may need replacing OR There is a load on the battery causing the battery to fail Analysis

FREQUENTLY ASKED QUESTIONS

Q. How do I know if the battery is charged?

A. The charger's FULLY CHARGED LED will illuminate (solid). Alternatively use a Battery Hydrometer (Projecta Part No. BH100). A reading of 1.250 or more in each cell indicates a fully charged battery.

Q. I have connected the charger properly but the 'CHARGING LED' does not come on?

A. In some cases batteries can be flattened to the point where they have very little or no voltage. This can occur if a small amount of power is used for a long time, for example a map reading light is left on for a week or more. Projecta 7 Stage chargers are designed to charge from as little as 2.5 Volts.

If the voltage is lower than 2.5 Volts use a pair of booster cables to connect between two batteries to provide more than 2.5 Volts to the battery being charged. The charger can then start to charge the battery and the booster cables can be removed.

Q. Can I use the charger as a power supply

A. Yes, by selecting Power Supply mode you are able to use the charger as a power supply to run an appliance. Ensure the appliance being run is not greater than the charger's output current and where possible connect the charger to a battery, and the battery to the appliance.

The charger may also be used to connect to a vehicle while changing the battery to maintain the vehicles computer and radio settings.

Q. Why does the charger reset when I connect a load directly to the battery charger in Power Supply mode.

A. The charger will reset when in Power Supply mode if the load exceeds the chargers capacity. Some appliances when turned on or first connected to the charger will cause the charger to reset and it will re-try by slowly ramping up its output.

Q. How can I tell what stage the battery charger is in?

A. Below are the conditions that are displayed by the LEDs for each of the charge stages.

	Desulphation	Soft Start	Bulk	Absorption/ Equalisation	Analyse	Recondition	Float
Red LED ● Power							
Blue LED ● Charging (Fast Flash)	- - - - (Slow Flash)	————	————		- - - -	
Green LED ● Full				- - - -	- - - -	- - - -	————

Q. What happens if my battery charger is in Desulphation mode or Soft Start mode, but I want to start bulk charging?

A. Desulphation mode is time limited to 6 hours and Soft Start is limited to 1 hour. If you can not wait for the battery charger to move through these stages you can select Power Supply mode to charge the battery. After an hour of charging in Power Supply mode, there should be sufficient charge in the battery to bypass both Desulphation and Soft Start. Select the correct battery chemistry type to continue charging the battery. Whilst in Power Supply mode the charger will output a full current up to 13.8V.

Q. What if I have an appliance connected to the battery whilst charging?

A. Powering an appliance while charging your battery will impact on the battery chargers ability to accurately measure the battery's response to the charge being applied. The battery charger has been designed to accommodate this situation although not recommended.

For optimum charging it is recommended to charge without any appliance load on the battery. Power Supply mode is recommended when an appliance is connected to a battery and is drawing power.

Q. Can I select a different battery chemistry for charging my battery?

A. Yes the battery chemistry selection can be different to your battery type if the charge voltages match the battery manufacture's recommendations.

Q. Why does CALCIUM mode take so long to charge?

A. To fully charge a Calcium battery, the battery requires an extra charging stage called 'Equalization'. This consists of a constant current being fed into the battery until 16V is reached. This rejuvenates the battery cells. This charging stage can take up to 12 hours.

Q. Why do I need a special Calcium mode?

A. Because of the different chemistry used to make a Calcium battery, a different charging algorithm (or technique) is required. Calcium batteries are also affected when deeply discharged or used heavily. They need to be recharged by a Calcium charger to fully recharge the battery and to maximize the battery's life and performance.

Q. What is a Calcium battery?

A. Calcium batteries are lead acid batteries that have had calcium added to the lead plates, either to one plate (called Calcium Hybrid) or to both plates (called Calcium-Calcium).

The added calcium provides a number of benefits:

- i. Lower internal resistance which provides a small increase in CCA performance.
- ii. The ability to withstand higher engine bay temperatures.
- iii. Low self discharge rate, which increases the shelf life, typically 4 times longer than a Lead-Lead battery.



WARRANTY

Projecta Intelli-Charge battery chargers are covered by a 2 Year Warranty. Failure to follow the operating instructions may damage the charger and will void warranty. Please read these operating instructions carefully before use. For a warranty claim please return unit to the place of purchase with your sales receipt as proof of purchase date.

VICTORIA (HEAD OFFICE)

Brown & Watson International Pty Ltd
Knoxfield, Victoria 3180
Telephone (03) 9730 6000
Facsimile (03) 9730 6050
National Toll Free 1800 113 443

WESTERN AUSTRALIA

Brown & Watson International Pty Ltd
22 Thorpe Close, Welshpool WA 6106
Telephone (08) 9451 4526
Facsimile (08) 9358 1445

NEW SOUTH WALES

Brown & Watson International Pty Ltd
PO Box 995
Campbell Town, NSW 2560
Facsimile (02) 4628 3403
National Toll Free 1800 113 443

QUEENSLAND

Brown & Watson International Pty Ltd
2A/3375 Pacific Highway,
Underwood QLD 4119
Telephone (07) 3808 2482
Facsimile (07) 3208 3137

SOUTH AUSTRALIA

Brown & Watson International Pty Ltd
5 Phillips Street, Thebarton SA 5031
Telephone (08) 8443 3018
Facsimile (08) 8443 3008

NEW ZEALAND

Narva New Zealand Ltd
22–24 Olive Road
PO Box 12556 Penrose
Auckland, New Zealand
Telephone (09) 525 4575
Facsimile (09) 579 1192