

INTELLI-RV

12V POWER MANAGEMENT SYSTEM



P/No. PM300-BT

IMPORTANT SAFETY INFORMATION

Please read this manual thoroughly before use and store in a safe place for future reference.

WARNINGS

- Explosive gases. Prevent flames and sparks. Provide adequate ventilation during charging
- Before charging, read the instructions
- For indoor use. **Do not** expose to rain
- For charging Lead Acid and LiFePO₄ batteries **only** (of the size & voltage specified in the specification table.
- Always charge the battery on the correct voltage setting. Never set the charger to a higher voltage than the battery
- Disconnect the 240V mains supply before making or breaking the connections to the battery
- The battery charger must be plugged into an earthed socket outlet
- Connection to supply mains is to be in accordance with national wiring rules
- Do not attempt to charge non-rechargeable batteries
- Never charge a frozen battery
- If the AC cord is damaged, do not attempt to use. It must be replaced or repaired by a qualified technician
- Corrosive substances may escape from the battery during charging and damage delicate surfaces. Store and charge in a suitable area
- This charger is not intended for use by persons (including children) with reduced physical, sensory or mental capabilities, or lack of experience and knowledge, unless they have been given supervision or instruction concerning the use of the appliance by a person responsible for their safety
- Young children should be supervised to ensure that they do not play with the appliance
- If the recreational vehicle is to be put in to storage without power, please turn off the BATTERY MASTER SWITCH. If the recreational vehicle is to be put in to long term storage without power, disconnect ALL cabling from the battery.

CONTENTS

1. INTRODUCTION	4
1.1 Features	5
1.2 Monitor	6
1.3 Water tank probe	6
2. KEY FEATURES AND FUNCTIONS	6
2.1 Multiple inputs	6
2.2 Battery charger of stationery/service battery	6
2.3 Vehicle battery charger	7
2.4 Power supply mode	7
2.5 MPPT solar charger controller	7
2.6 Voltage charging relay (VCR)	7
2.7 Categorised outputs	8
2.8 Battery low voltage protection	8
2.9 Manual battery switch	8
2.10 Precise battery measurement	8
2.11 Silent mode	8
3. STRUCTURE AND INSTALLATION	9
3.1 PM300-BT Power Management System	9
3.2 Monitor	10
3.3 Water tank probe	11
3.3.1 PMWS400 water tank probe	11
3.3.2 PMWS200 water tank probe	11
4. WIRING	12
4.1 Material	12
4.2 System schematic	13
4.3 Preparation	14
4.4 Connection	14
5. DISPLAY	15
5.1 PM300-BT Master Power Unit	16
5.2 Monitor PMLCD-BT	16
5.2.1 Monitor symbol explanation	16
5.2.2 Switch explanation	17
5.2.3 Alphabet explanation	17
6. OPERATION	18
6.1 Configuration on PM300-BT	18
6.1.1 Battery capacity and battery type	18
6.1.2 Select switch local/remote	19
6.2 Configuration on monitor	19
6.2.1 Monitor configuration menu	20
6.3 Maintenance	21
6.3.1 Battery monitor maintenance	21
6.3.2 Daily maintenance	21
7. TROUBLE SHOOTING	22
7.1 L.E.D Display on PM300-BT Unit	22
7.2 Error code on monitor	22
8. SPECIFICATION	23

1. INTRODUCTION

PM300-BT is designed for use in caravans or motor homes. The unit has integrated functions such as: battery charger, distribution blocks, MPPT solar charger controller, charging relay, Low Voltage Disconnect (LVD), water pump controller, water tank indicator and LCD Display.

The PM300-BT is designed for an easy installation and a user-friendly interface.

SYSTEM COMPONENTS:

1. Master Power Unit
2. Monitor
3. 4 Water tank sensors (Not supplied)
4. Cables (Refer to Chapter 4.1 for the cable list)

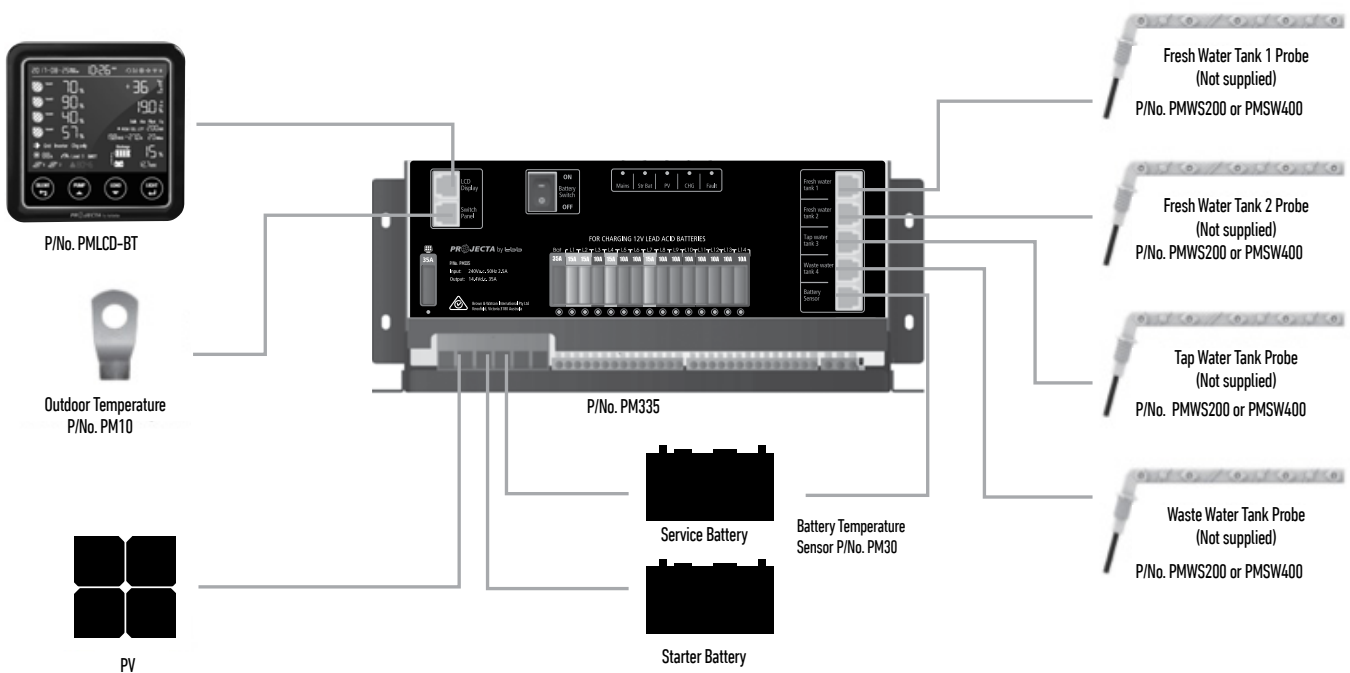

Figure 1 System Components for PM300-BT

1.1 Features

- Smart battery charger 12V 35A (30A for charging current)
- Multi stage adaptive charging algorithm
- Active Power Factor Correction (PFC) charging
- Temperature compensation charging
- Voltage compensation charging
- Float Charge for starter battery
- Solar charge controller (MPPT), 30A
- 14 built in fused outputs
- Charging from Alternator at 12V 60A - 60A continuously, 100A 30mins
- Low battery voltage protection
- Built-in battery switch to isolate the battery when in storage
- Built-in shunt for precise battery measurement
- 1 water pump control with up to 4 connections for water sensors
- Thermal control fan
- Spring terminal and screw terminal
- T-bus compatible

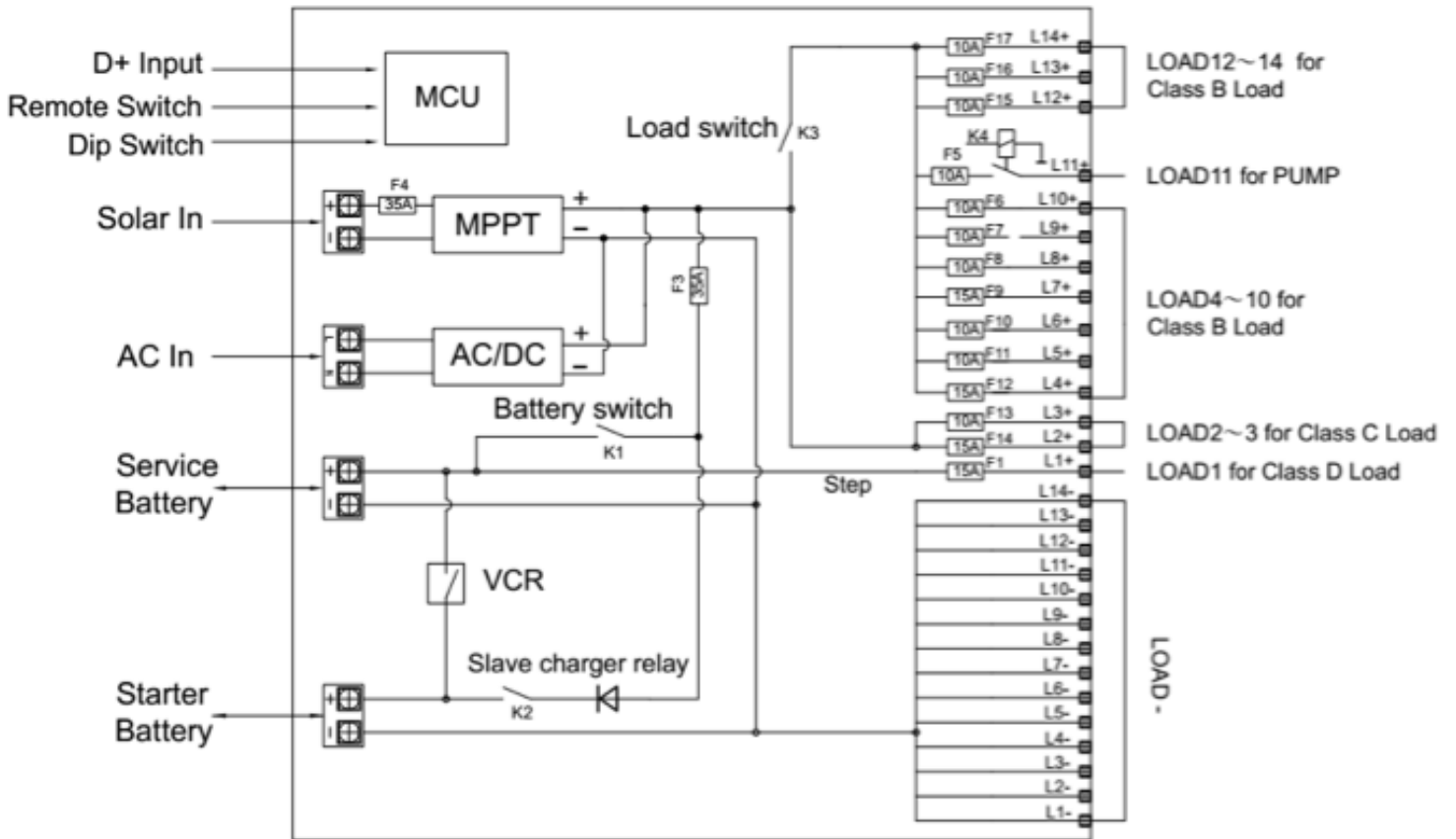

Figure 2 System Schematic

1.2 Monitor PMLCD-BT

The monitor is a digital control center for complete on-board power.

FEATURES:

- T-Bus design (can be connected to multiple devices)
- System monitoring
- Configuration
- Built-in Bluetooth for pairing to smart phone



Figure 3 Overview of Monitor

1.3 Water Tank Probe

For PM300-BT, a maximum of 4 probes can be monitored.

NOTE: Always check the probe required for the water tank before purchase.

There are 2 probe styles:

PMWS200:

- Side installation
- Suitable for water tank
- Depth >200mm

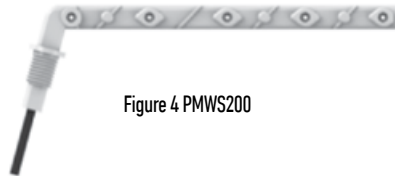

Figure 4 PMWS200

PMWS400:

- Side installation
- Suitable for water tank
- Depth 300-400mm

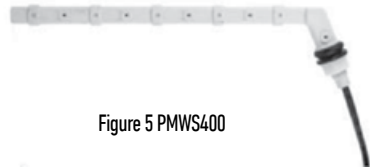

Figure 5 PMWS400

2. KEY FEATURES AND FUNCTIONS

2.1 Multiple Inputs

The PM300-BT accepts inputs from AC mains, solar panel and starter battery. However, only one source will provide power at one time, see Table 1 at right for details.

AC MAINS	X	X	
SOLAR	X		X
STARTER BATTERY		X	X
DOMINATING SOURCE	AC MAINS	AC MAINS	STARTER BATTERY

Table 1 Multiple inputs

2.2 Battery Charger Of Stationery/Service Battery

The charger automatically starts when the appropriate qualified power is connected, either from grid, generator or solar.

With multiple charging stages (soft start-bulk absorption float-recycle), PM300-BT is designed to fully charge battery quickly. To guarantee the optimal charging for batteries of different states, the PM300-BT features Microprocessor-controlled charging algorithm. The Float and Recycle charging programs guarantees that the battery condition does not change despite being connected for a longer period.

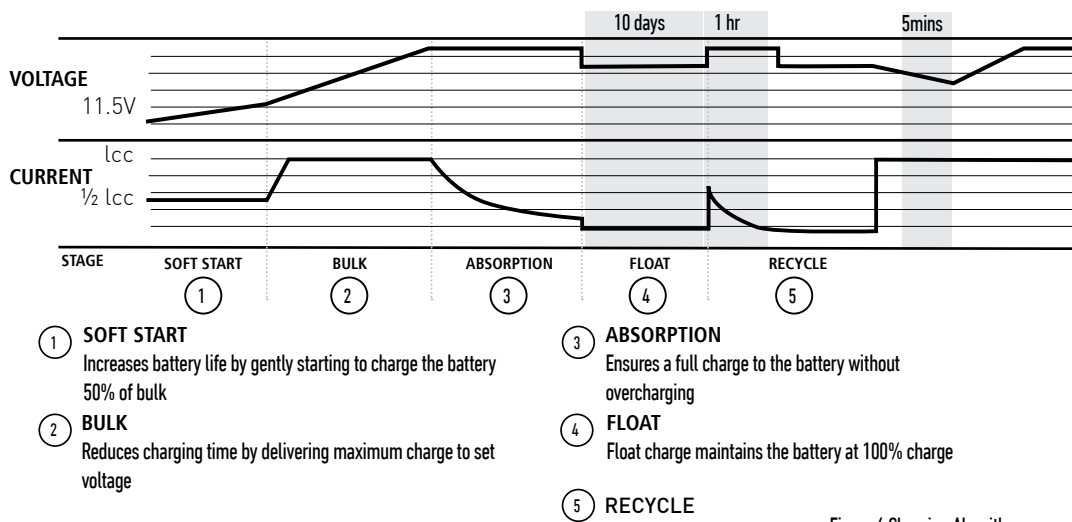

Figure 6 Charging Algorithm

Battery Temperature Sensor

The BTS, P/No. PM30 (Battery Temperature Sensor) supplied with PM300-BT, measures the temperature of the battery and automatically adjusts, in real time, to charge the battery properly at compensation rate of $-4\text{mv} \pm 10\%/^{\circ}\text{C}/\text{cell}$. In case BTS is not present, the PM300-BT will use 25°C as default.

Voltage Compensation Charging

With a voltage sensor the PM300-BT can automatically adjust its output to compensate the voltage drop caused by a cable. This assures the right voltage is being delivered for optimal charging.

Adjustable Charging Capacity

Users can adjust the charging current by specifying the battery capacity. The charging current is set at threshold rate of 10% the of the battery capacity ($I = 0.1C$) by default.

Lithium Battery Charging

The PM300-BT can be configured to charge Lithium battery. With the Lithium battery, the max charging current will automatically be set at 30% of battery capacity ($I_{\text{max}}=0.3C$).

2.3 Vehicle Battery Charger

Along with a powerful charger for service battery, PM300-BT offers a float charge of up to 3A to keep the starter battery charged, whether connected to the AC main or PV. When the starter battery is less than 12.4V, the PM300-BT starts charging after 30 minutes delay and stops charging when voltage reaches 12.8V.

2.4 Power Supply Mode

If no battery is attached to PM300-BT unit, it will work as a power supply automatically with a 12.8VDC output.

2.5 MPPT Solar Charger Controller

PM300-BT has a built-in MPPT charger for the service battery with:

- Max input voltage 50VDC
- Max charging current 20A
- Max supply current 30A

2.6 Voltage Charging Relay (VCR or commonly known as a VSR)

PM300-BT master power unit has a built-in voltage charging relay (VCR), which offers a convenient source to charge the service battery by alternator whilst engine is running.

LEAD ACID BATTERY – When the starter battery reaches 13.4VDC with threshold time delay, the VCR will charge the service battery from the alternator. The VCR will continue the charging until the starter battery voltage drops under 12.8VDC.

LiFePO₄ LITHIUM BATTERY – When the starter battery reaches 14.0VDC with threshold time delay, the VCR will charge the service battery from the alternator. The VCR will continue charging until the starter battery voltage drops below 13.5VDC with less than 2A charge to the service battery with threshold time delay.

NOTE: The PM300-BT, when charging from the starter battery, does not provide the 5 stage charge.

It simply takes whatever power and charging is available from the alternator.

NOTE: PM300-BT If your vehicle is fitted with a smart charging system (Variable Voltage or Temperature Compensating), the VCR charge system may not function correctly and a DC-DC Charging system is recommended.

Please consult your local dealer or installer for further information.

2.7 Categorical Outputs

The 14 outputs are categorised into groups and controls as per below:

TYPE	QTY	DESCRIPTION	POSSIBLE LOAD SUITABLE
Class A1	1	Relay controlled output with fuse, protected by main master switch relay	Water pump
Class B	10	Fused outputs, protected by master switch relay	Ventilation fan etc
Class C	2	Live load	Fridge, security alarm etc.
Class D	1	Permanent on load	Auto step

Table 2 Categorical outputs

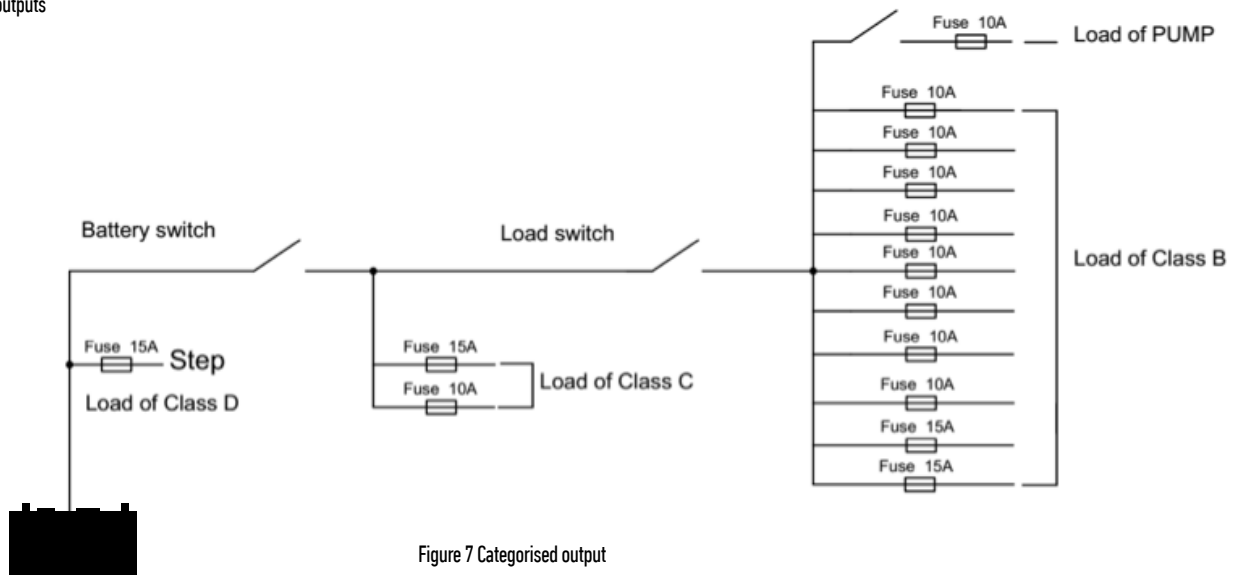

Figure 7 Categorical output

2.8 Battery Low Voltage Protection (BLVP or commonly known as an LVD)

PM300-BT master power unit has a built-in low voltage protection relay. It will disconnect the load once the battery voltage drops below the threshold voltage. The default setting is 10.5VDC. This switch can be manually turned On/Off via the LOAD button on the LCD display.

2.9 Battery Switch

The PM300-BT unit offers a convenient way to switch off the output of the service battery on-board. It protects the service battery from being drained by electronics on board, completely isolating the battery. PM300-BT unit also supports a remote manual battery switch. Before using the remote switch, ensure the 'switch selector' is set to 'Remote'.

The switch is only effective when the system has no other energy resource for the load except the battery.

2.10 Precise Battery Measurement

PM300-BT unit has a battery measurement system controlled by microprocessor. It measures battery voltage, charge/discharge current, remaining AH and display time to go.

Compared to conventional indicating meters, a small current can be measured and read accurately with this device. With this feature, it highlights faults, alarms and installation errors.

NOTE: If you have loads connected directly on battery instead of PM300-BT Power Management System, the measurement will not be accurate.

2.11 Silent Mode

In Silent Mode, the backlight of the monitor and the fan will be turned off or decreased in speed.

3. STRUCTURE AND INSTALLATION

3.1 PM300-BT Power Management System

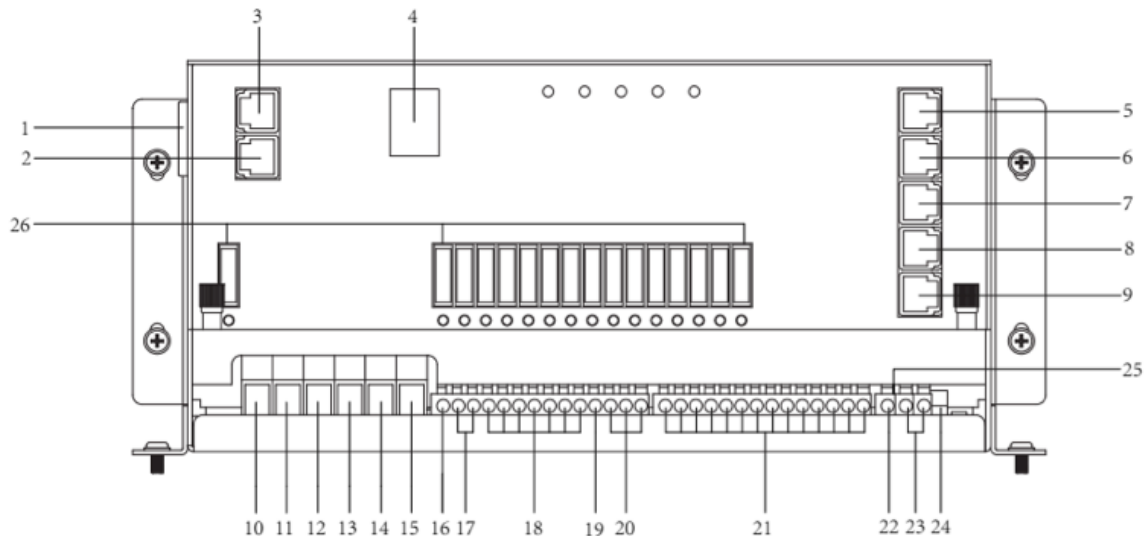

Figure 8 Front panel of PM335

N°	LABEL	DEFINITION	DESCRIPTION
1	AC Mains	AC input port	
2	Switch panel	Comm port	Connect to switch panel (Switch panel is not available on PM300-BT)
3	LCD Display	Comm port	Connect to Monitor
4	Battery switch	Service battery switch	Manual battery switch
5	Fresh water tank 1		Connect to fresh water tank 1
6	Fresh water tank 2		Connect to fresh water tank 2
7	Tap water tank 3		Connect to tap water tank
8	Waste water tank 4		Connect to waste water tank
9	Battery sensor	For temp compensation	Connect to service battery+
10	PV+	Solar input	Connect to solar panel + terminal
11	PV-	Solar input	Connect to solar panel - terminal
12	Starter Bat+	Starter battery+	Connect to starter battery+ (<20Vdc)
13	Service Bat+	Service battery+	Connect to service battery+ (<20Vdc)
14	Starter Bat-	Starter battery-	Connect to starter battery-
15	Service Bat-	Service battery-	Connect to service battery-
16	L1+	Step	Connect to load of class D
17	L2+ ~ L3+		Connect to load of class C
18	L4+ ~ L10+		Connect to load of class B
19	L11+	Water pump	Connect to Water pump+
20	L12+ ~ L14+		Connect to load of class B
21	L1- ~ L14-		Connect to DC load -
22	D+ Point	D+ input	Connect to D+
23	Remote Switch	Terminal block	Connect to remote switch
24	Select Switch	Dip switch	Select local switch or remote switch (NOTE: open the upper cover board to operate)
25	Setting	Dip switch	Set the battery type and capacity (NOTE: open the upper cover board to operate)
26	Fuse		Fuses and fuse failure indication

Table 3 Categorized outputs

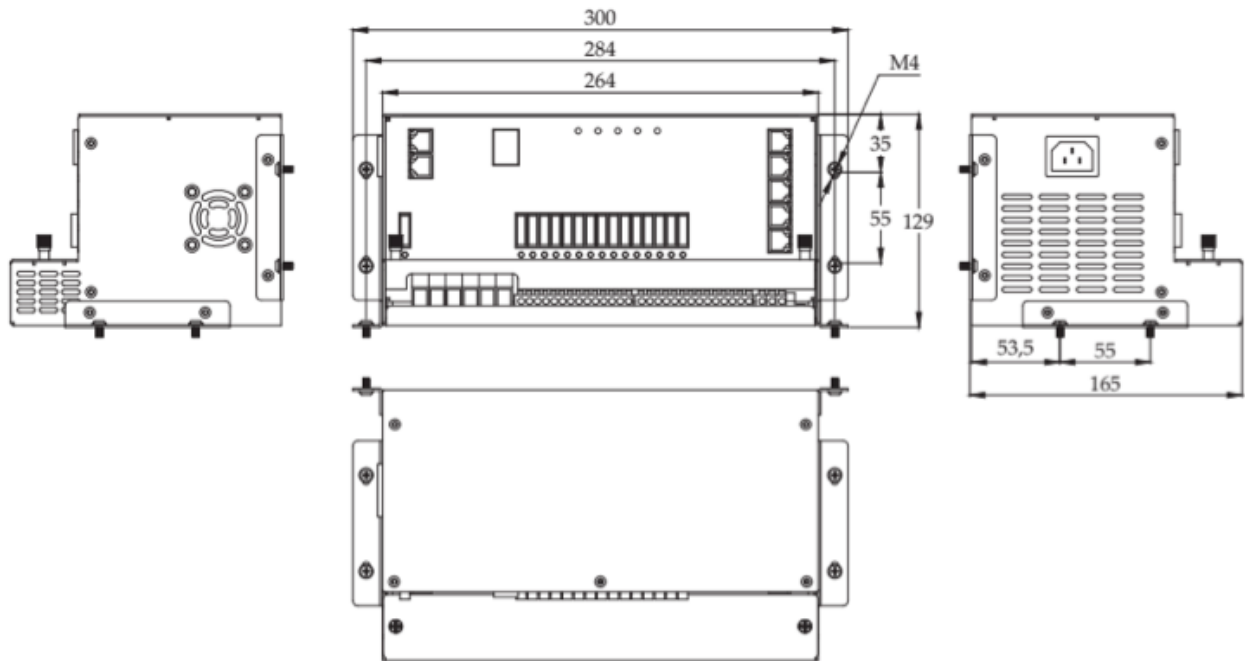
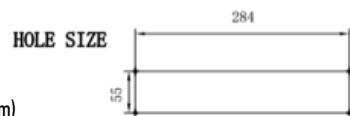
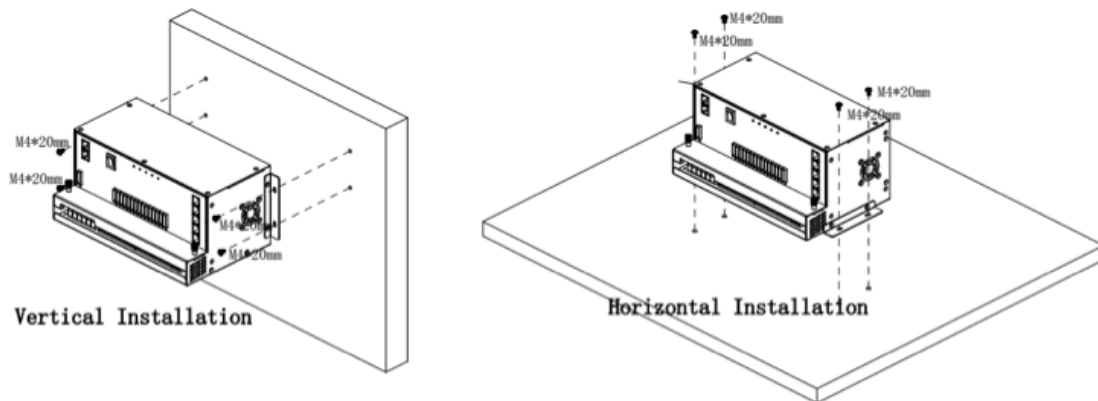

Figure 9 Dimension of PM335 (Unit: mm)

Installation:

PM335 can be installed on a horizontal surface or vertically on a wall. Please see following instructions:



Ensure clearance on both sides of PM335 unit upon installation. A recommended clearance of 5cm on each side.

Figure 10 Installation of PM335 (Unit: mm)

3.2 Monitor

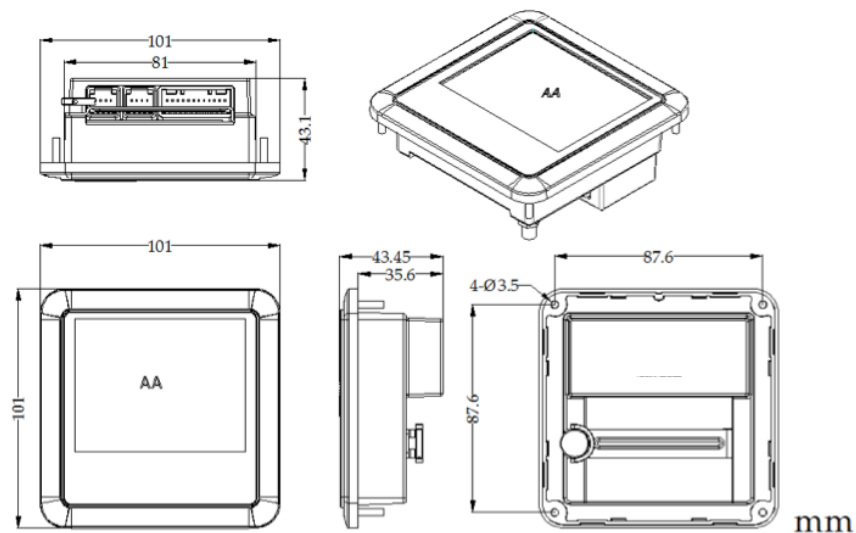

Figure 11 Dimension of Monitor PMLCD-BT (Unit:mm)

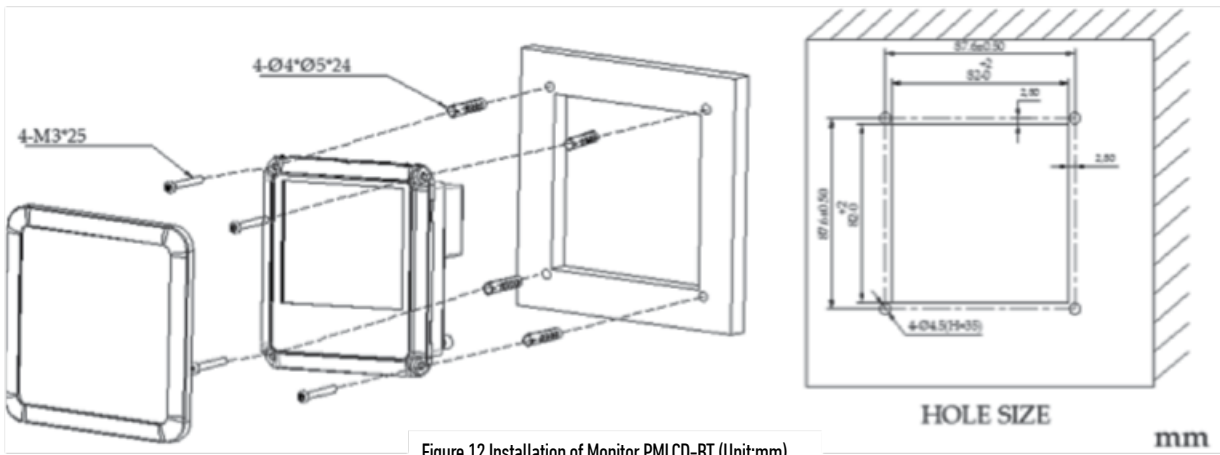

Figure 12 Installation of Monitor PMLCD-BT (Unit:mm)

3.3 Water Tank Probe

3.3.1 PMWS400 Water Tank Probe

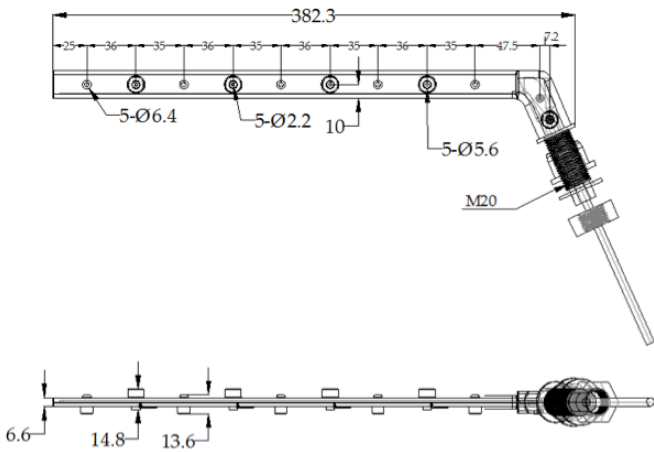

Figure 13 Dimension of PMWS400 (Unit:mm)

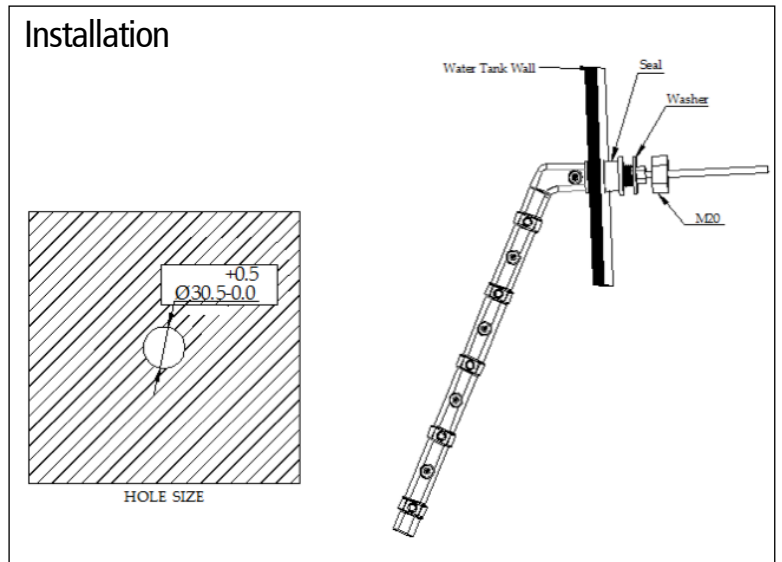

Figure 14 Installation of PMWS400

3.3.2 PMWS200 Water Tank Probe

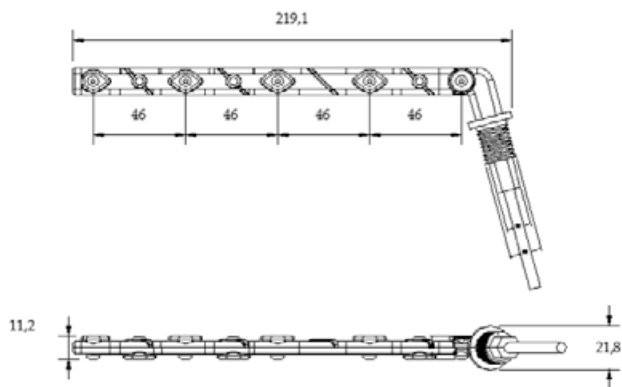

Figure 15 Dimension of PMWS200 (Unit:mm)

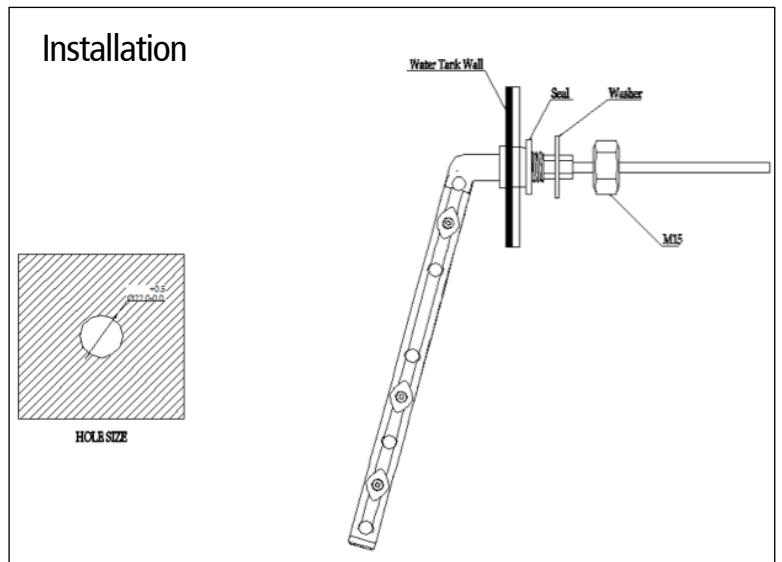

Figure 16 Installation of PMWS200

4. WIRING

4.1 Material

CODE	NAME	MODEL/LENGTH	QTY	P/No. ON DRAWING
1	Power Management System	PM335	1	1
2	Monitor	PMLCD-BT	1	2
3	Fresh water tank 1 level sensor	Not included and to be ordered separately	0	4
4	Fresh water tank 1 level sensor		0	5
5	Tap water tank level sensor		0	6
6	Waste water tank level sensor		0	7
7	Solar		0	9
10	Communication line (RS485)	5m	1	PMLCDC
11	Temperature line	5m	1	PMTS
12	Battery sensor line	3m	1	PMBS
13	Water tank probe line	Not included	0	PMWS200 / PMWS400
14	Water tank probe line		0	
15	Water tank probe line		0	
16	Water tank probe line		0	
17	Power Cable	1.5m	1	PMAC

Table 4 Component List of PM300-BT

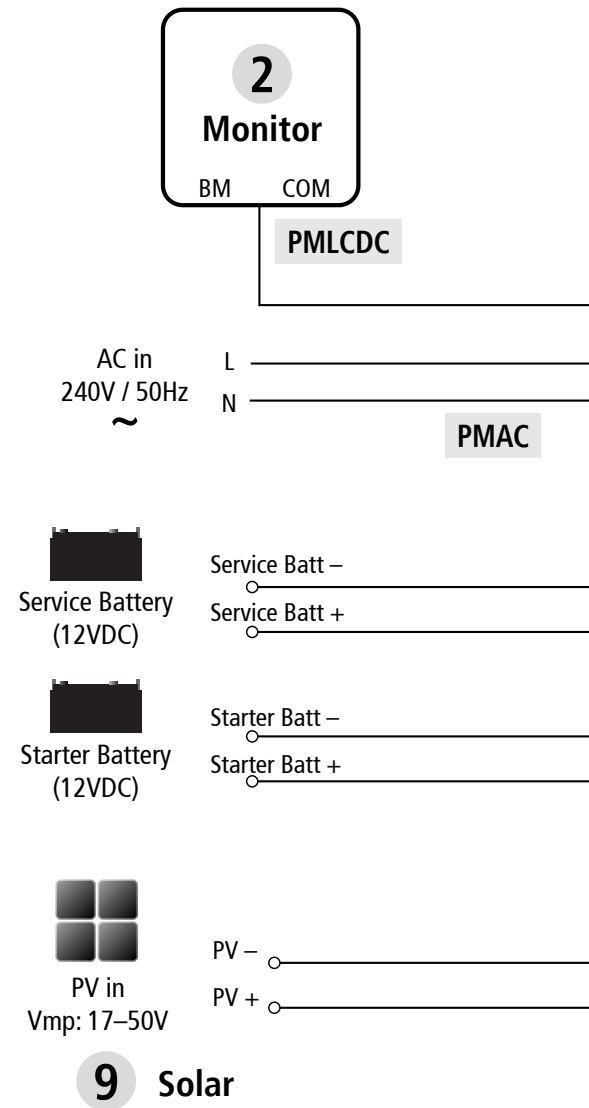

4.2 System Schematic

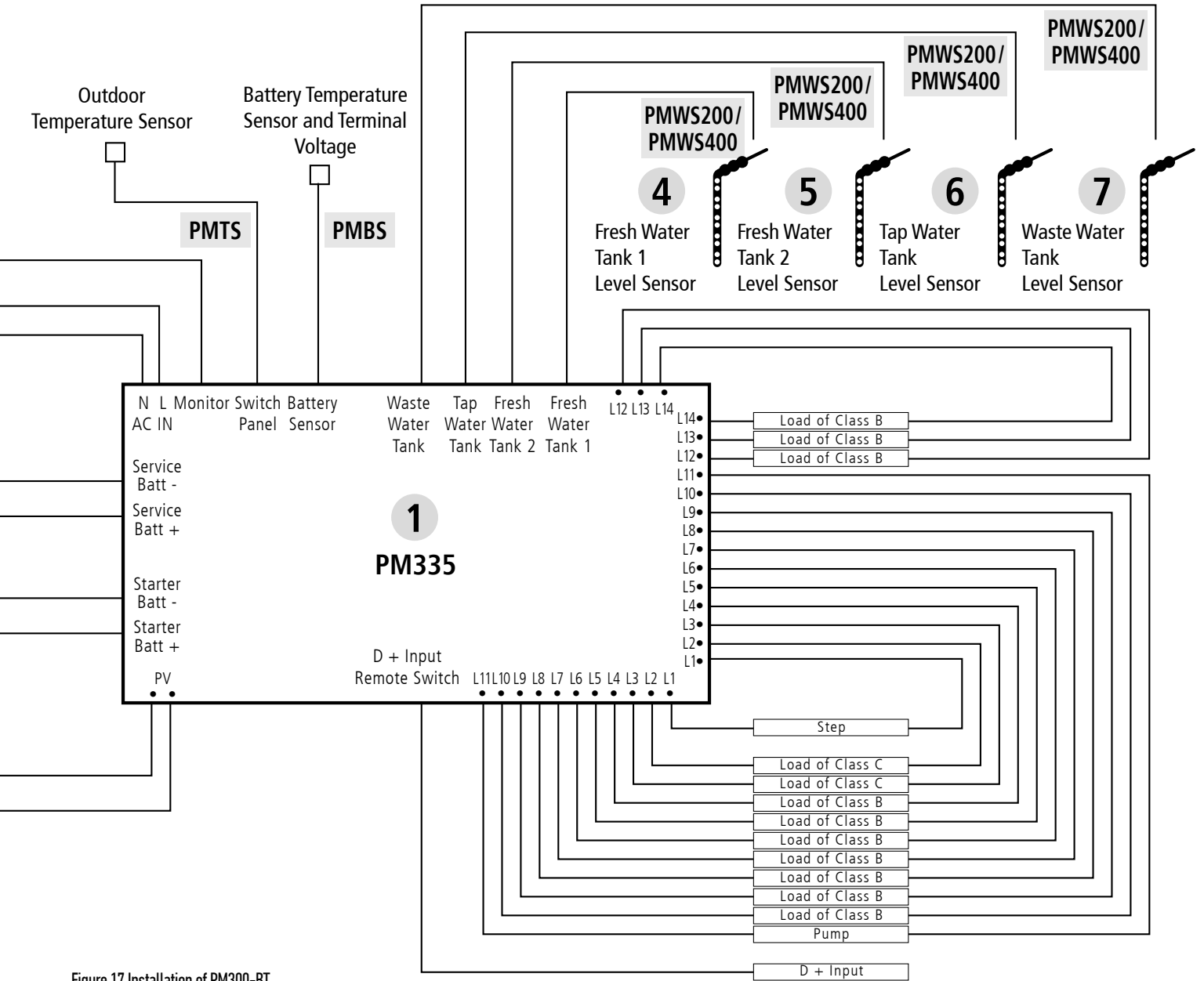

Figure 17 Installation of PM300-BT

4.3 Preparation

PM300-BT system is designed with concept of 'Plug in and Play' in mind. To complete the easy installation, a screw driver and DC cables are required. Follow Table 5 recommendation for minimum wirings.

CURRENT	MINIMUM CABLE SIZE
0-5A	1.0mm ² or 18 AWG
5-10A	2.0mm ² or 14 AWG
10-15A	3.0mm ² or 13 AWG
15-20A	4.0mm ² or 11 AWG
20-25A	5.0mm ² or 10 AWG
25-30A	6.0mm ² or 9 AWG

Table 5 Minimum cable size



When running cables, if they pass through panels or wall, ensure the cables are protected from damage by sharp edges. In such cases, it is recommended to use cable glands.

4.4 Connection

PM300-BT unit is designed with a spring and screw terminal. Please refer to following illustration at right. Each type of terminal is designed to fit a different range of cables.

TYPE	TERMINAL MODEL NUMBER	SUITABLE CABLE GAUGE
Type 1	ERTB10-10.16	0.5mm ² - 10mm ²
Type 2	wago804-114	0.25mm ² - 2.5mm ²

Table 6 Recommended terminal and cable gauge

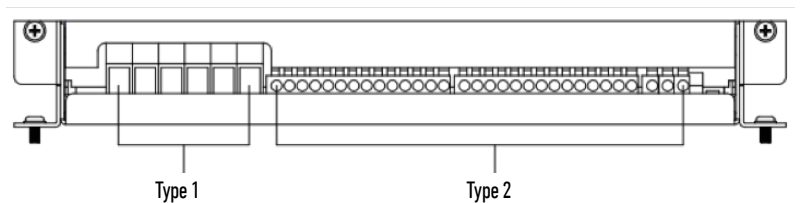

Figure 18 PM335 Terminal

TYPE 1

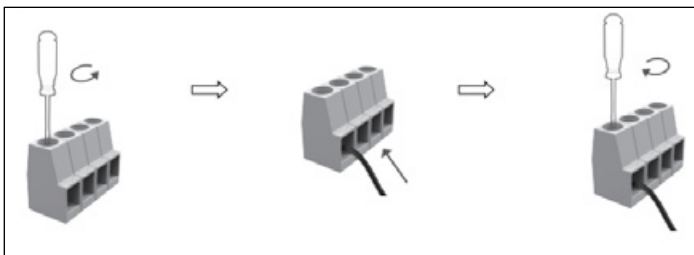

Figure 19 Connection of Terminal Type 1

TYPE 2

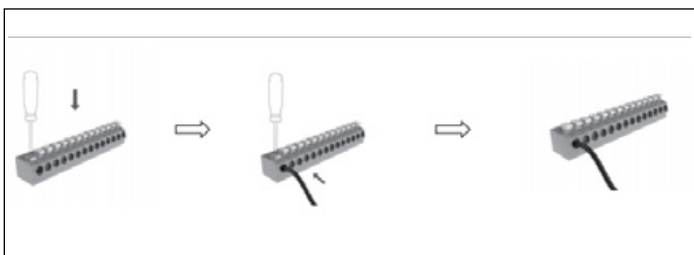

Figure 20 Connection of Terminal Type 2

5. DISPLAY

5.1 PM300-BT Power Management System

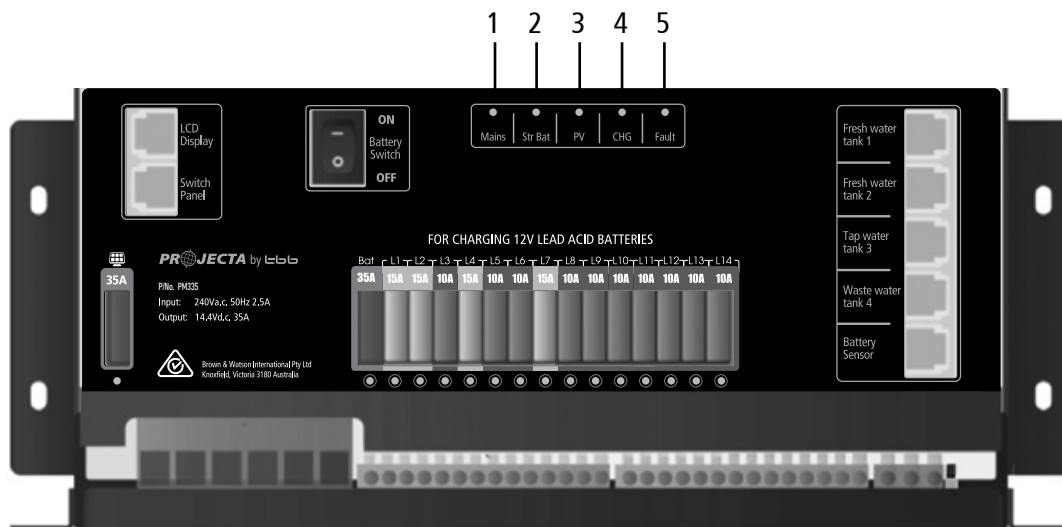

Figure 21 An overview of PM335

No.	LED	COLOUR	STATUS	DESCRIPTION
1	Mains	GREEN	ON	AC input OK
			OFF	AC disconnected
			Quick flashing (flash twice every second)	AC input abnormal
2	Str Bat	GREEN	ON	Alternator charging the SERVICE battery
			Slow flashing (flash once every second)	Starter battery is >13.4V and is being charged by the AC
			Quick flashing (flash twice every second)	The Starter Battery is 2~13.4V or >16.0V, while AC power is connected.
			OFF	Starter battery is disconnected.
3	PV (Solar)	GREEN	ON	Solar charging the battery
			Slow flashing (flash once every second)	The input voltage of the Solar is normal but it is charged by the AC or Starter battery
			Quick flashing (flash twice every second)	Solar input voltage error – Solar voltage >50Vdc
			OFF	Solar disconnected
4	CHG	GREEN	ON	Battery charged
			Slow flashing (flash once every second)	Battery charging
			Quick flashing (flash twice every second)	Battery discharge
			OFF	Battery disconnected
5	FAULT	RED	ON	Short circuit
			Flash once per cycle	Service battery voltage low
			Flash twice per cycle	Service battery voltage high
			Flash 3 times per cycle	PM335 unit Over Temperature
			Flash 4 times per cycle	Bulk charge timeout
			Flash 5 times per cycle	VCR anomaly
			Flash 6 times per cycle	Environment Over Temperature

Table 7 LED indicator description of PM335

5.2 Monitor PMLCD-BT



Figure 22 An overview of monitor

The PMLCD-BT monitor can be paired to a smart phone via the BWI-PM300 App. This App will display the battery parameters, water tank levels, allow pump control and load isolation. Refer to the PM300-BT App Operation Manual for Bluetooth pairing procedure.

5.2.1 Monitor Symbol Explanation











No.	DESCRIPTION	COMMENTS	
1	Water level	0%-25%-50%-75%-100%	
	Water Tank 1	EMPTY	Flashing, the water is less than the recommended level
	Water Tank 2		
	Water Tank 3		
	Water Tank 4		
	FULL	Flashing, the gray water or waste water is more than the alarm level	
2	Working Mode	GRID	AC grid status
		CHARGE ONLY	Battery charger only
3	Load		Status of DC-Load switch in system: on / off
		BATTERY	DC loads are powered by battery
4	Water Pump		Pump 1 is ON
			Pump 1 is OFF
5	Alarm Error Code		Overload alarm
			Over temperature alarm
			System error code. Refer to the error codes on page 20
6	VCR connection		Voltage charging relay (VCR) is connected
			Voltage charging relay (VCR) is disconnected
7	Output power		Voltage of system output
			Current of system output

Table 8 Symbol Explanation

5.2.2 Switch Explanation









SWITCH	FUNCTION	DESCRIPTION
SILENT & 	Stop the fan ventilation in order to reduce the noise Refer to 2.11	Press 'Silent/Esc' button until  shows on the screen, then press 'Light/Enter'.
PUMP & 	To switch on/off pump	Pump on:  Pump off:  The detailed steps are shown as below Figure 23
LOAD & 	To switch off all the loads connected on DC charger	The function is the same as load switch in PM4SW10. The detailed steps are shown as below Figure 24
LIGHT 	To adjust the brightness and switch off the backlight of the monitor	Total three levels of brightness
LIGHT For Setting 	To set clock, battery battery tank quantity etc	Hold down the 'LIGHT' button until the Date zone (Table 16) shows the setting code. It means the unit enters the setting mode. For the full details of setting codes, please refer to Chapter 6.2.1

Table 9 Switch Explanation

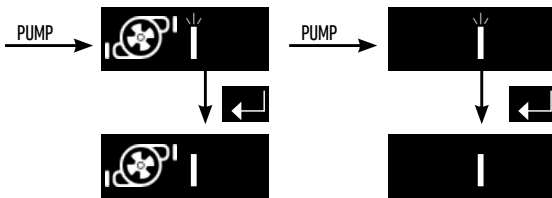

Figure 23 Switch ON /OFF Pump

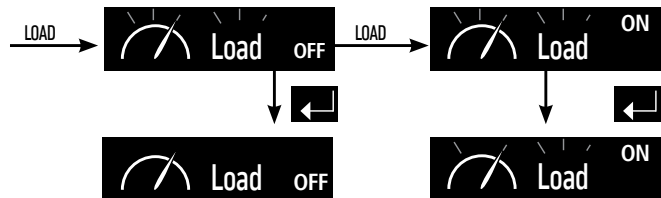

Figure 24 Switch ON /OFF all of the DC Loads

5.2.3 Alphabet Explanation

CHARACTER	A	b	C	d	E	F	g	H	I	J	K	L	M	N	O	P	q	r	S	t	U	v	Y	y
ALPHABET	A	B	C	D	E	F	G	H	I	J	K	L	M	N	O	P	Q	R	S	T	U	V	X	Y

Table 10 Alphabet code

6. OPERATION

If there is conflict between the configuration on PM300-BT and the monitor, the monitor will flash as a reminder.

6.1 Configuration on PM335

Configuration of the battery type and capacity can be done through the App, Monitor or PM335 master power unit.

6.1.1 Charging Current and Battery Type

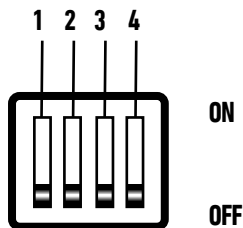

Figure 25 Dip Switch of PM335

Dip switch definitions:

DIP SWITCH	1	2	3	4
	Charging Current		Battery Type	

Table 11 Dip Switch definition

Configure the Max Charging Current of PM335:

		LEAD ACID		LITHIUM
DS1	DS2	AC CHARGE	SOLAR CHARGE	AC / SOLAR CHARGE
ON	ON	10A	20A	30A
ON	OFF	15A	30A	30A
OFF	ON	20A	30A	30A
OFF	OFF	30A	30A	30A

Table 12 Battery capacity setting by dip switch



When choosing max charging current, please take into consideration the consumption of the DC load connected with the system.

Configure the Battery Type Installed:

DS3	DS4	BATTERY TYPE	ABSORPTION	FLOAT
OFF	OFF	AGM	14.4V	13.5V
OFF	ON	GEL	14.1V	13.5V
ON	OFF	LFP (LiFePO ₄)	14.4V	13.5V
ON	ON	WET	14.7V	13.7V

Table 13 Battery type setting by dip switch

Factory default setting:

DIP SWITCH	1	2	3	4
STATUS	OFF	OFF	OFF	OFF

Table 14 Factory default setting



Settings of 'Battery Type' and 'Battery Capacity' need to be the same at both the PM335 dip switch and the monitor.



When the battery type and capacity setting on the monitor is not the same as PM335 dip switch, the icons will be flashing.

Figure 26 Reminder when conflict setting between PM335 and monitor

6.1.2 Select Battery Switch Local/Remote

This function offers a possibility for user to use a remote battery switch to power on/off the service battery output

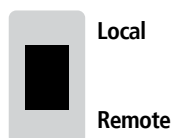

DIP SWITCH	DESCRIPTION
Local	The switch on PM335 unit works
Remote	The remote switch works and local one is disabled

Figure 27 Local/Remote Select Switch Table 15 Local/Remote Setting

6.2 Configuration on Monitor

Access to the configuration menu is safeguarded with a passcode. The default is 0000 and may be set by a user.

Passcode Descriptions

0000	Factory Default, no passcode
1999	Factory access passcode
XXXX	User define

Press the 'Light' button until the setting code is showing on the date time area which means the monitor is ready for configuration. The 'PUMP' button and 'LOAD' button can be used to scroll through the configuration menu.

CODE	FUNCTION	DESCRIPTION
CLOC	Time Setting	Set date system 12H/24H and date.
BATE	Battery Setting	
	TYPE	Battery Type AGM / GEL / LFP (LiFePO ₄)/WET
	CAPA	Battery Capacity
	BLVP	Battery Low Voltage Protection To shutdown the output of loads
PUMP	Pump	Pumps enable or disable
	PUMP1	Pump 1 Select Pump 1
	PUMP1 ON	Pump 1 ON Pumps 1 enable
	PUMP1 OFF	Pump 1 OFF Pump 1 disable
FACTRY	Restore factory defaults	
	CANCEL	Cancel Cancel to restore factory defaults
	ACCEPT	Accept Confirm to restore factory defaults
VER	Version	Software version of devices. read only
	CMP	CMP Software Version of PM335
	LCD	LCD Software Version of LCD
BLE RAD	Cut off Bluetooth	Shut down connection of Crystal to APP
UPDATE EN	Update enable	Enable to update firmware

Table 16 Setting code of the Monitor

6.2.1 Monitor Configuration Menu

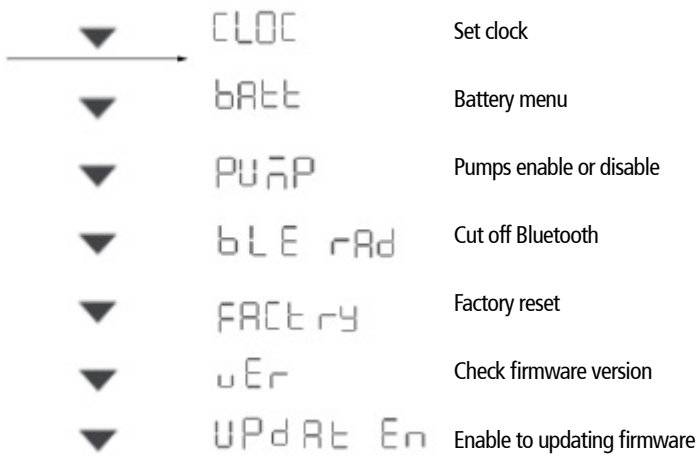

Figure 28 Main menu of setting

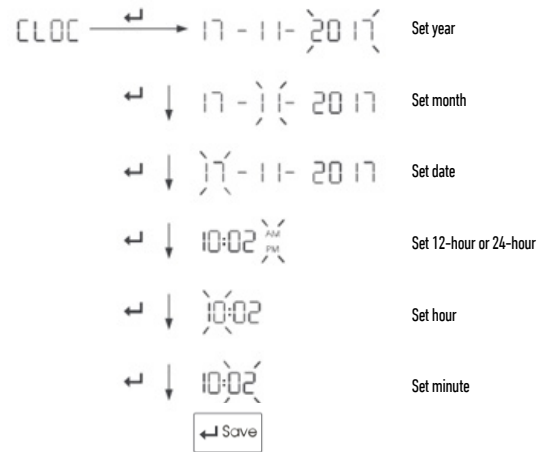

Figure 29 Date and Time setting



Figure 30 Battery Type setting

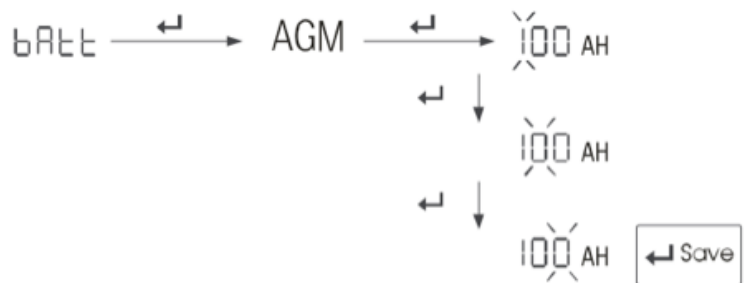

Figure 31 Battery Capacity setting



Figure 32 Low Voltage Protection setting



Figure 33 Water Pump Enable/Disable setting



Figure 34 Restore factory setting

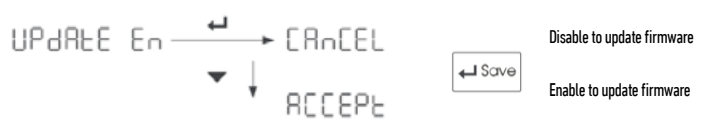

Figure 35 Update firmware

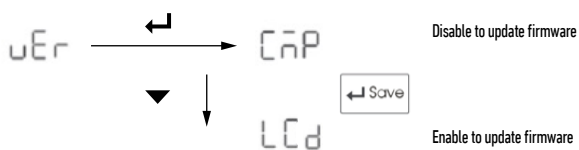

Figure 36 Check firmware version



Figure 37 Cut off the Bluetooth connection

6.3 MAINTENANCE

6.3.1 Battery Monitor Maintenance

There is a built-in battery measurement in the PM300-BT system. To assure the accuracy, maintain the system with the following instructions:

1. Fully charge the battery from AC grid instead of PV every 2 weeks.
2. Do a full charge to the battery every 3 months.
 - Charge the battery with AC grid until the 'CHG' LED light on PM335 unit or 'FLOAT' shows on the monitor
3. When replacing the existing battery with a new one, please have the new battery fully charged by Grid for the first time to calibrate a precise battery SOC.



Every 3 months, the monitor will display a code (8018) suggesting maintenance. If you have performed maintenance and would like to turn off this alarm, press 'SILENT' button for 1s. Only the energy consumption of the loads connected on the PM335 is measured and calculated in the data on the Monitor.

6.3.2 DAILY MAINTENANCE

- Confirm the Battery Switch is turned on when you want to charge the battery with the AC grid.
- Check the nominal battery voltage is 12VDC.
- Ensure the space (5cm each side) beside the PM335 unit for the appropriate ventilation.

7. TROUBLE SHOOTING

7.1 L.E.D Display on PM335

No.	LED	COLOUR	STATUS	DESCRIPTION
1	Mains	Green	Quick flashing (flash twice every second)	AC input abnormal
2	Str Bat	Green	Quick flashing (flash twice every second)	The Starter Battery is 2~13.4V or >16.0V, while AC power is connected.
3	PV	Green	Quick flashing (flash twice every second)	Solar input voltage error – Solar Input >50Vdc
4	Fuse LED	Red	Solid	Fuse blown, need to check load and replace fuse
5	Fault	Red	ON	Short circuit
			Flash once per cycle	Service battery voltage low
			Flash twice per cycle	Service battery voltage high
			Flash 3 times per cycle	PM300-BT unit over temp
			Flash 4 times per cycle	Bulk charge timeout
			Flash 5 times per cycle	VCR anomaly
			Flash 6 times per cycle	Environment over temp

Table 17 Error LED indicator of PM335

7.2 Error Code on Monitor

ERROR CODE	DESCRIPTION
8001	Lose communication
8003	Battery voltage low
8004	Battery voltage high
8005	PV voltage low
8006	PV voltage high
8010	Battery temperature high
8011	Battery temperature low
8012	Internal temperature high
8013	Starter battery voltage low

ERROR CODE	DESCRIPTION
8014	Starter battery voltage high
8015	Over load
8016	Output short circuit
8017	Module protection
8018	Battery maintenance notice
8027	VCR connect is error
8028	VCR disconnect error
8030	Environment temperature is high
8031	Bulk stage time-out

Table 18 Error Code List

8. SPECIFICATION

MODEL		PM335
ELECTRICAL SPECIFICATIONS		
Grid	Nominal input voltage (V)	240±10%VAC 50/60Hz
	Power factor	0.95
	Input current at full load	2.5A
Battery	Starter Battery	12VDC
	Starter battery voltage range	12.8-16VDC
	Service battery	12VDC
	Service battery voltage range	10.5-16VDC
PV	Charger type	MPPT
	Open circuit voltage	50VDC
	Max supply current	30A
	Max charging current	20A
Charging Relay	Relay specification	12VDC 60A continuous, peak current 100A, 30mins
	Connect voltage	Lead Acid - 13.4VDC LiFePO ₄ - 14.0VDC
	Connect delay time	10sec
	Disconnect voltage	Lead Acid - 12.8VDC LiFePO ₄ - 13.5VDC<2A
	Disconnect delay time	60sec
	High voltage limit	16.0VDC
Charger Mode	Charge Algorithms	5 Stage
	Battery type	AGM/GEL/LFP (LiFePO ₄)/WET
	Start voltage	2V
	Bulk current	30A (Max)
	Absorption voltage	(14.4/14.1 /14.4/14.7) ±0.15VDC
	Float voltage	(13.5/13.5 /13.5/13.7) ±0.13VDC
Power Supply Mode	Nominal output voltage	12.8±0.2 VDC
	Rated output current	35A (Continuous)
Efficiency		88%
Working temperature		-40°C~+65°C (50°C:full load; 60°C:20A; 65°C: shutdown the output)

MODEL		PM335	
ELECTRICAL SPECIFICATIONS			
Battery Disconnect (LVD)	Disconnect voltage	AGM/GEL/WET	10.5VDC (default)
		LFP (LiFePO ₄)	11.2 VDC (Default)
	Delay off time	60 sec	
	Reconnect voltage	AGM/GEL/WET	11.5VDC (default)
LFP (LiFePO ₄)		12.2 VDC (Default)	
Current draw on Battery	240VAC is off, no vehicle charging	490mA	
	Load switch off	255mA	
	LVD off, Service<10.5V current draw on battery	120mA	
	Battery switch OFF <10V draw on battery	0mA	
Fused outputs	Numbers	14	
	Rated Current	15A x 4: 10A x 10	
Protection	Short circuit on output	Fuse blown	
	Reverse polarity	Diode reverse isolation	
	Overload protection	Derate the output until overload is removed	
	Battery charger over temperature	Shut down PM335	
	Ambient over temperature	Alarm	
	Battery over voltage limits	Battery charger disconnect, loads disconnect	
PHYSICAL SPECIFICATIONS			
Dimensions (L*W*H)	264 × 164 × 128mm		
Weight	3kgs		
Enclosure	Steel Case		
Battery Connector	M4 Screw (16mm ²)		
Load Connector	Wago804-114 (2.5mm ²)		
Cooling	Forced cooling		
Protection category	IP20		
Approvals			
Electrical	AS/NZS 60335.2.29		
EMC	CISPR14		

Table 19 Specification of PM335

WARRANTY STATEMENT

Applicable only to product sold in Australia

Brown & Watson International Pty Ltd of 1500 Ferntree Gully Road, Knoxfield, Vic., telephone (03) 9730 6000, fax (03) 9730 6050, warrants that all products described in its current catalogue (save and except for all bulbs and lenses whether made of glass or some other substance) will under normal use and service be free of failures in material and workmanship for a period of one (1) year (unless this period has been extended as indicated elsewhere) from the date of the original purchase by the consumer as marked on the invoice. This warranty does not cover ordinary wear and tear, abuse, alteration of products or damage caused by the consumer.

To make a warranty claim the consumer must deliver the product at their cost to the original place of purchase or to any other place which may be nominated by either BWI or the retailer from where the product was bought in order that a warranty assessment may be performed. The consumer must also deliver the original invoice evidencing the date and place of purchase together with an explanation in writing as to the nature of the claim.

In the event that the claim is determined to be for a minor failure of the product then BWI reserves the right to repair or replace it at its discretion. In the event that a major failure is determined the consumer will be entitled to a replacement or a refund as well as compensation for any other reasonably foreseeable loss or damage. This warranty is in addition to any other rights or remedies that the consumer may have under State or Federal legislation.

IMPORTANT NOTE

Our goods come with guarantees that cannot be excluded under the Australian Consumer Law. You are entitled to a replacement or refund for a major failure and compensation for any other reasonably foreseeable loss or damage. You are also entitled to have the goods repaired or replaced if the goods fail to be of acceptable quality and the failure does not amount to a major failure.

Distributed by

AUSTRALIA

Brown & Watson International Pty Ltd

Knoxfield Victoria 3180
Telephone (03) 9730 6000
Facsimile (03) 9730 6050
National Toll Free 1800 113 443

NEW ZEALAND

Narva New Zealand Ltd

22–24 Olive Road
PO Box 12556 Penrose
Auckland New Zealand
Telephone (09) 525 4575
Facsimile (09) 579 1192

IS457

Issue 2021/03