

## IDC CHARGE LINK

P/No. PMIDCLK

### INSTALLATION INSTRUCTIONS

If an IDC25, IDC25L or IDC45 is to be used with the INTELLI-RV PM2xx, PM3xx or PM4xx series, IDC Charge Link will need to be installed into Starter Battery and Service Battery.

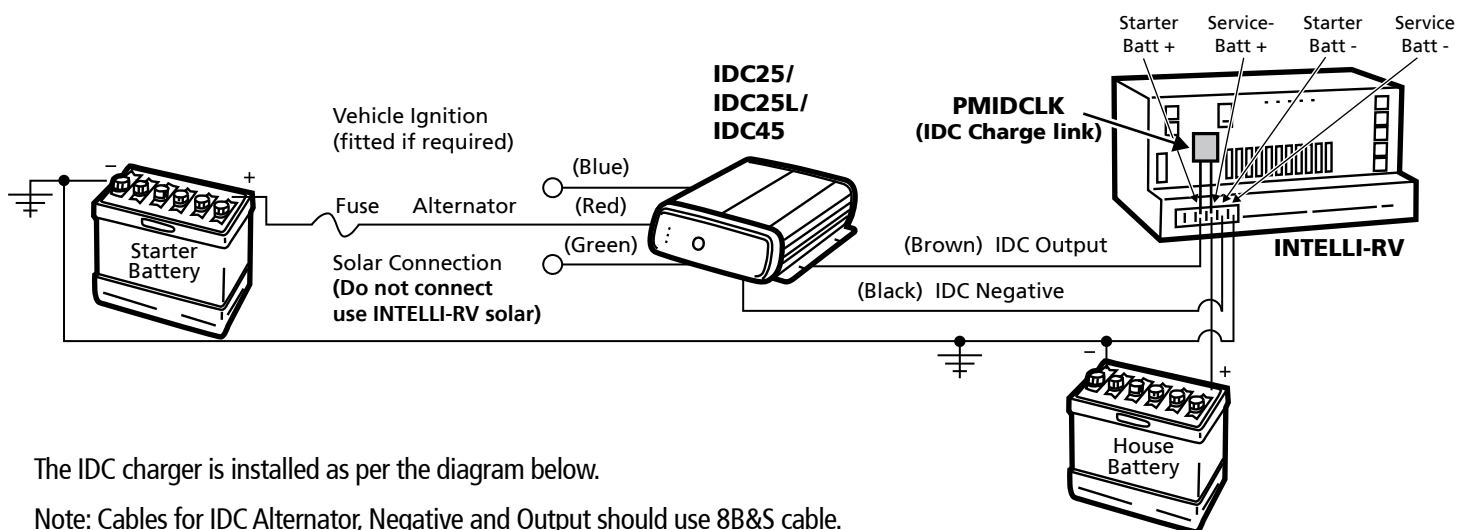
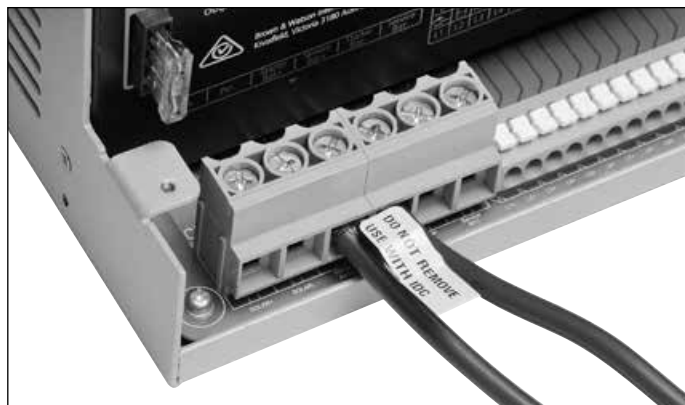

The IDC charger is installed as per the diagram below.

Note: Cables for IDC Alternator, Negative and Output should use 8B&S cable.

BATTERY TYPE	IDC 25/45 Mode	INTELLI-RV (PM2xx, 3xx, 4xx)
Gel	Gel	Gel
AGM	AGM	AGM
Wet (Flooded Inc. Calcium)	Wet	Wet

BATTERY TYPE	IDC25L Mode	INTELLI-RV (PM2xx, 3xx, 4xx)
Lithium (LiFePO <sub>4</sub> )	Charge	LFP (LiFePO <sub>4</sub> )

Distributed by  
AUSTRALIA

**Brown & Watson International Pty Ltd**  
Knoxfield, Victoria 3180  
Telephone (03) 9730 6000  
National Toll Free 1800 113 443

NEW ZEALAND

**Griffiths Equipment Ltd**  
Mount Wellington, Auckland 1060  
Telephone (09) 525 4575

#### WARRANTY STATEMENT

Applicable only to product sold in Australia & New Zealand

Brown & Watson International Pty Ltd of 1500 Ferntree Gully Road, Knoxfield, Vic., telephone (03) 9730 6000, fax (03) 9730 6050, warrants that all products described in its current catalogue (save and except for all bulbs and lenses whether made of glass or some other substance) will under normal use and service be free of failures in material and workmanship for a period of one (1) year (unless this period has been extended as indicated elsewhere) from the date of the original purchase by the consumer as marked on the invoice. This warranty does not cover ordinary wear and tear, abuse, alteration of products or damage caused by the consumer. To make a warranty claim the consumer must deliver the product at their cost to the original place of purchase or to any other place which may be nominated by either BWI or the retailer from where the product was bought in order that a warranty assessment may be performed. The consumer must also deliver the original invoice evidencing the date and place of purchase together with an explanation in writing as to the nature of the claim. In the event that the claim is determined to be for a minor failure of the product then BWI reserves the right to repair or replace it at its discretion. In the event that a major failure is determined the consumer will be entitled to a replacement or a refund as well as compensation for any other reasonably foreseeable loss or damage. This warranty is in addition to any other rights or remedies that the consumer may have under State or Federal legislation.

#### IMPORTANT NOTE

Our goods come with guarantees that cannot be excluded under the Australian Consumer Law. You are entitled to a replacement or refund for a major failure and compensation for any other reasonably foreseeable loss or damage. You are also entitled to have the goods repaired or replaced if the goods fail to be of acceptable quality and the failure does not amount to a major failure.