

12V DC POWER MANAGEMENT BOARD



SYSTEM INTRODUCTION

Projecta's range of 12V power management systems are ideal for Ute canopies, 4WD's and Caravans. Choose from a range of pre-built models to suit your vehicles needs. Each model includes a DC/DC charger with solar and alternator inputs along with an array of switches and sockets to manage your power needs. The boards also feature a convenient easy to read Bluetooth enabled LCD display to check the status of your auxiliary battery. Lastly, it offers a powerful pure sine wave inverter to run all your 240V appliances off grid.

SYSTEM COMPONENTS

- LCD Battery Monitor with Bluetooth enabled APP
- 500A Current Shunt
- DC-DC Charger with MPPT Solar Controller
- 5 x 20A Switches
- Dual USB Socket (total 3.1A)
- 2 x 50A Heavy Duty Connectors
- Accessory and Merit Socket
- 1KW/1.5KW/2KW/3KW Inverter
- Easily accessible fuse holders for each component
- Low Voltage Disconnect

KEY FEATURES

DC-DC CHARGER (IDC25X)

Providing up to 5 stage charge simultaneously from both solar and alternator inputs, this dual battery management system is ideal for many applications

PURE SINE WAVE INVERTER (IP1000, IP1500, IP2000 or IP3000)

Converts 12V power to 240V to allow the use of devices such as laptops and fridges on the go

BATTERY MONITOR (BM500-BT)

An intelligent and compact Bluetooth battery meter ideal for monitoring SOC% and general status. Check your battery status via the on-board LCD display or via phone APP

SOCKETS & SWITCH PANEL

Power and charge 12V devices with 2 USB sockets (total 3.1A), a merit socket and a cigarette lighter socket. 5 switches are included to control all your connections

LOW VOLTAGE DISCONNECT (LVD50)

A robust and compact unit that protects expensive deep cycle batteries from damage caused by over-discharge. The switch loads on the board are protected by this unit

Note: Manuals for IDC25X, BM500-BT, IP1000, IP1500, IP2000, IP3000 and LVD50 can be found on the Projecta website: <https://www.projecta.com.au>

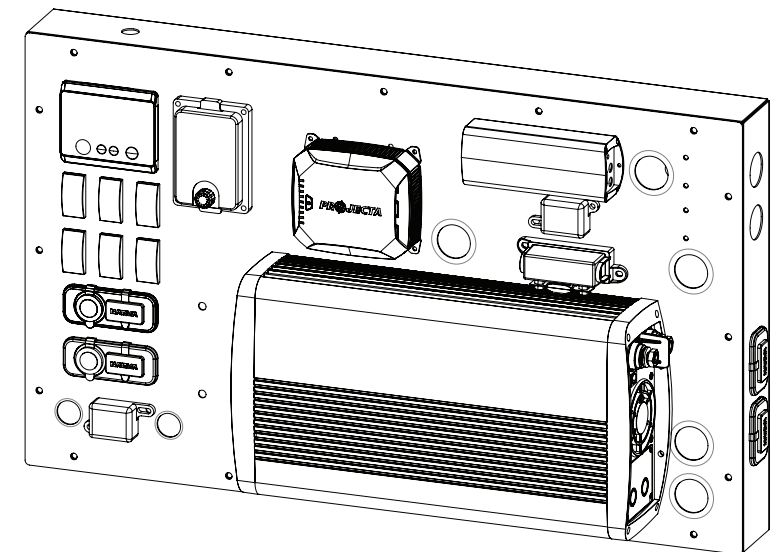
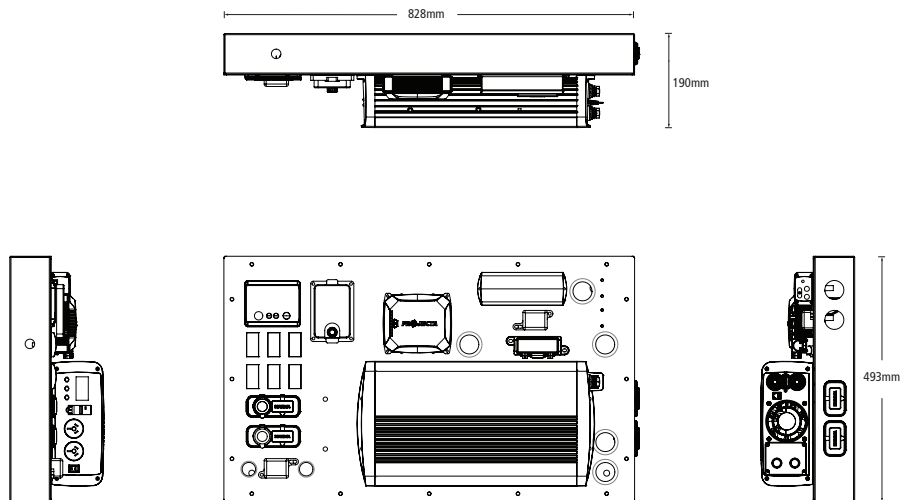

SAFETY WARNING

- Projecta Power Boards require installation into a vehicle, canopy or trailer. If you are unsure or not confident in 12V systems, then it is recommended that a qualified auto electrician is used.
- Always disconnect car batteries before working on 12V systems. Never work with a live 12V system as this can cause injury, damage to the product or damage to the vehicle's electrical system.
- Always use appropriate PPE when using power tools.
- Keep children & pets away from the Projecta Power Board.
- Use suitable gauge wiring when installing. If unsure then contact a qualified auto electrician.
- Do not insert any body parts or tooling in the 12V components.
- Install in a cool, dry, well-ventilated area.
- Ensure any exposed wires are covered.
- Ensure any input wiring is sufficiently insulated and protected from abrasion.
- Ensure input cables are adequately fused. Follow the instructions in this manual or contact a qualified auto electrician for correct fuse sizing.

To battery positive and negative terminals

Note: It is recommended to install a circuit breaker or high current fuse and fuse holder in the positive line as close to the battery as possible.

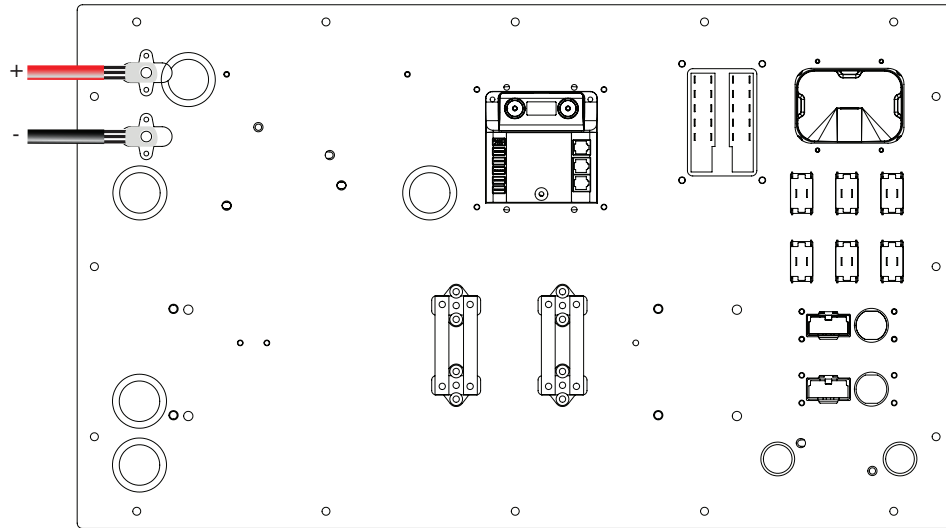

Figure 1

INSTALLATION INSTRUCTIONS

Step 1:

Remove Power Board from Box and dispose of packaging.

Step 2:

Remove the M5 bolts from the perimeter of the board.

Step 3:

Lift the front panel and secure the base bracket to the desired mounting location using bolts.

It is recommended to use 6 x M10 vibration resistant fasteners. See figure 2.

Wiring instructions:

Step 1:

Connecting to battery (battery and cable not supplied)

Loosen the nuts on the positive (red) and negative (black) posts located on the inside of the board. Select the appropriate cable gauge and attach the positive and negative cable (not supplied) from the battery to the positive (red) and negative (black) posts on the rear of the board. Ensure to add appropriate fusing. Feed the cable through the open grommet located on the side of the board. Tighten the connections securely. See Figure 1.

Step 2:

Connecting Solar and Alternator input

Ensure the input and solar connections are fitted with HD connectors that match those located on the right side of the board, then plug them into matching connection. Note the solar input should be unregulated and externally fused.

Step 3:

Connecting the Switches

The power board features 5 switches to control your output connections. Feed the open positive cable (see wire B in wiring diagram below) from the back of the switch through the closed grommet on the top or left side of the base bracket by cutting an opening in the grommet first. Wire to the positive side of the desired load (e.g light) and earth as necessary.

Note maximum load per switch is 20A

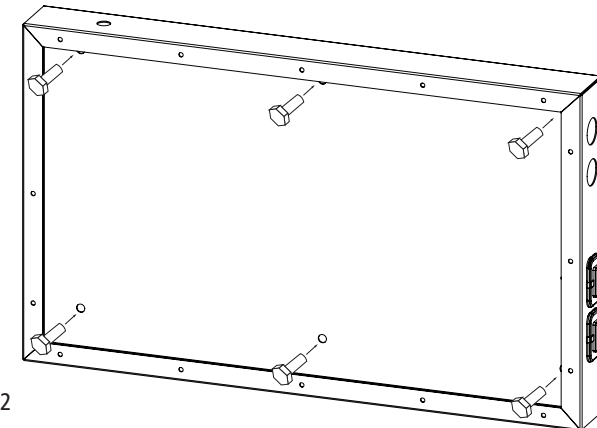
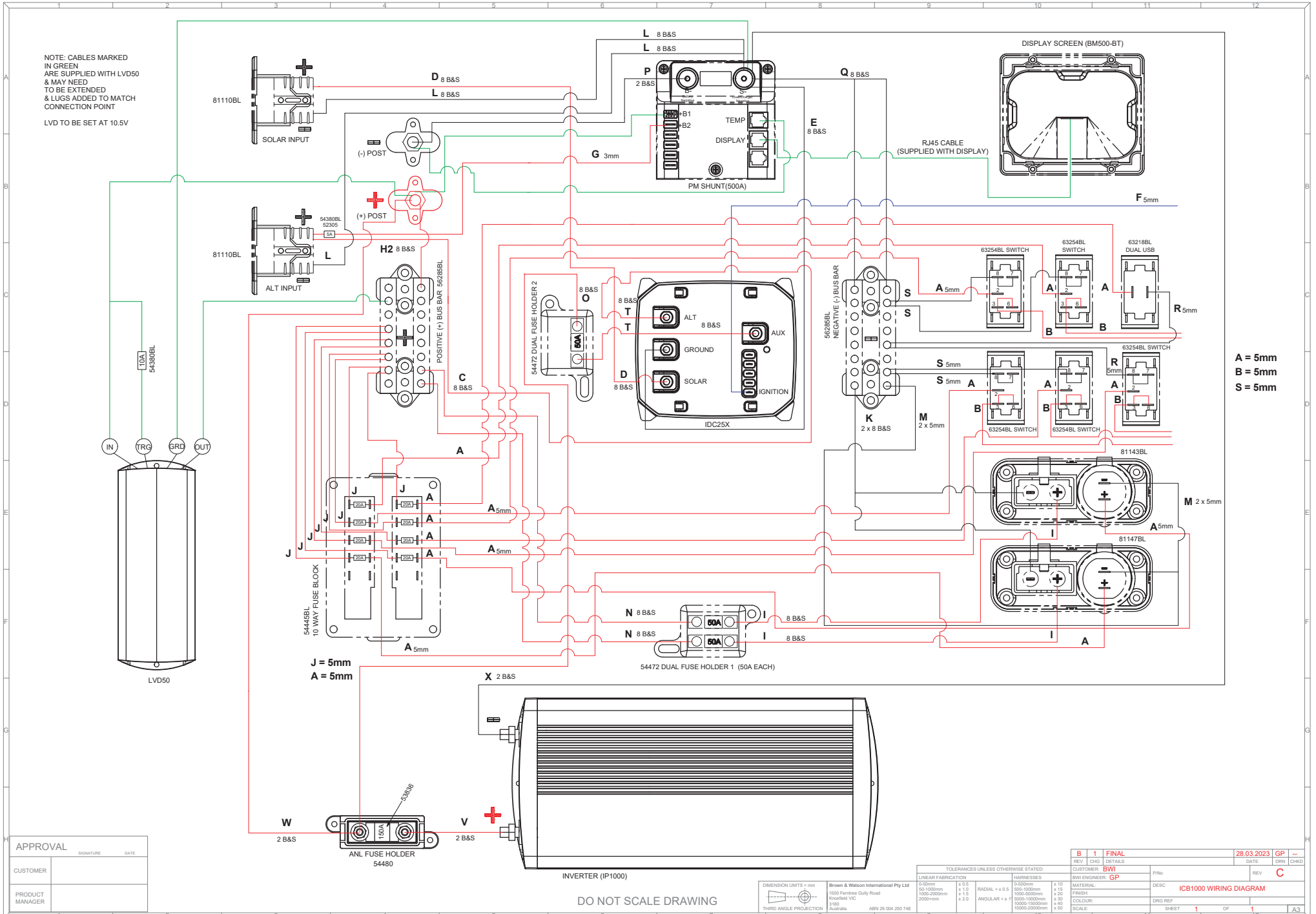

Figure 2

WIRING DIAGRAMS

NOTE: CABLES MARKED IN GREEN ARE SUPPLIED WITH LVD50 & MAY NEED TO BE EXTENDED & LUGS ADDED TO MATCH CONNECTION POINT
LVD TO BE SET AT 10.5V



A = 5mm
B = 5mm
S = 5mm

APPROVAL	
SIGNATURE	DATE
CUSTOMER	
PRODUCT MANAGER	

REV	CHG	DETAILS	DATE	1	DRN	CHKD
B	1	FINAL	28.03.2023	GP	--	--
CUSTOMER:		BWI	P/No:		REV C	
BWI ENGINEER:		GP	DESC:		ICB1000 WIRING DIAGRAM	
MATERIAL:						
FINISH:						
COLOUR:						
SCALE:						
DRG REF:						
SHEET		1	OF		1	A3

DIMENSION UNITS: mm
THIRD ANGLE PROJECTION
Brown & Watson International Pty Ltd
1403 Fernvale Gully Road
Knoxfield VIC
3114
Australia
ABN 29 004 250 748

TOLERANCES UNLESS OTHERWISE STATED:	
LINEAR FABRICATION	HARNESSES
0-50mm	±0.20mm
50-1000mm	±1.0
1000-2000mm	±1.5
2000-mm	±2.0
RADIAL	±0.5
ANGULAR	±1
	±0.5
	±50

DO NOT SCALE DRAWING

NOTE: CABLES MARKED IN GREEN ARE SUPPLIED WITH LVD50 & MAY NEED TO BE EXTENDED & LUGS ADDED TO MATCH CONNECTION POINT
LVD TO BE SET AT 10.5V

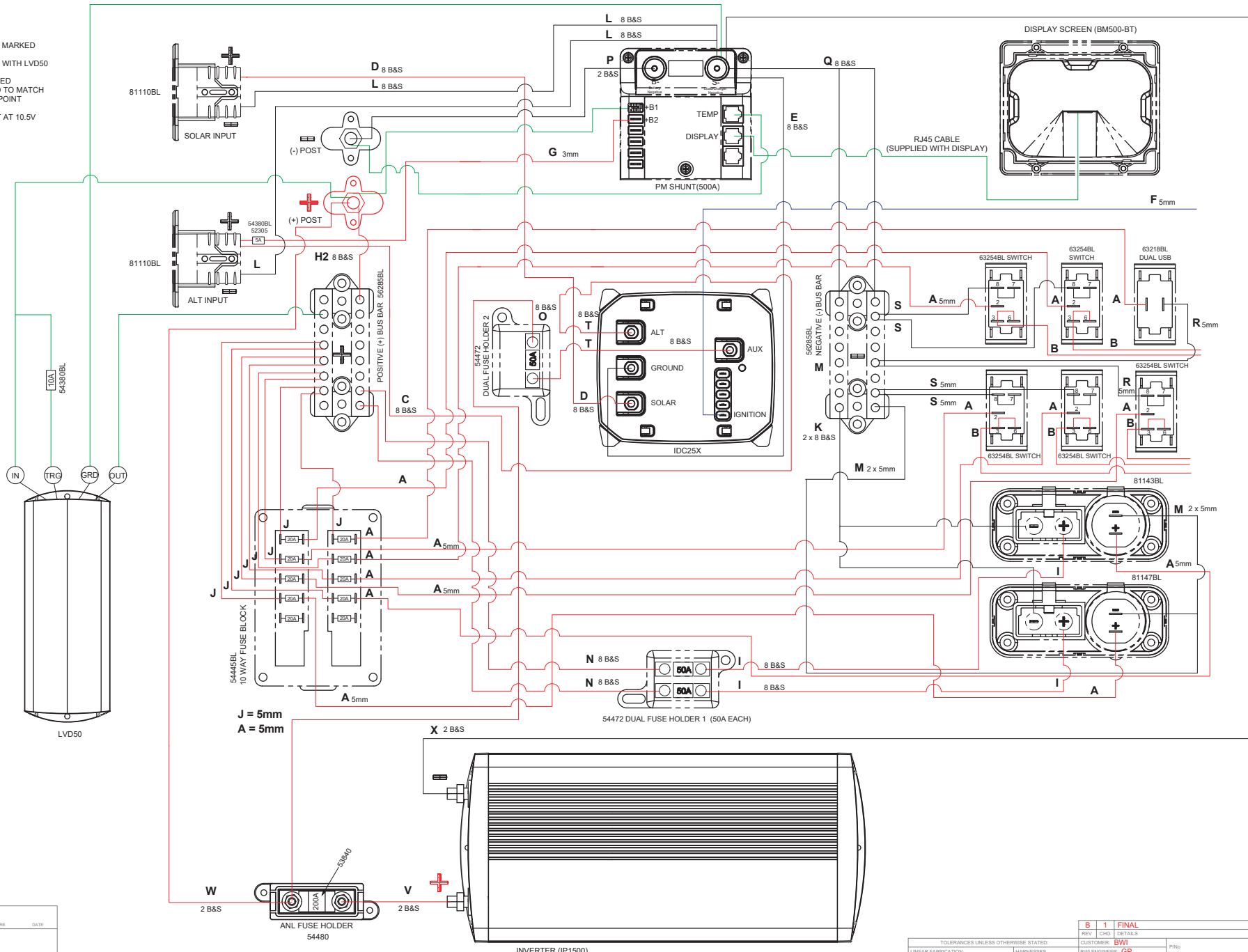

A = 5mm
B = 5mm
S = 5mm

DO NOT SCALE DRAWING

APPROVAL	
SIGNATURE	DATE
CUSTOMER	
PRODUCT MANAGER	

DIMENSION UNITS	mm
THIRD ANGLE PROJECTION	
Brown & Watson International Pty Ltd	
1500 Fernside Gully Road	
Knowlton VIC 3180	
Australia	
ABN 29 004 250 748	

TOLERANCES UNLESS OTHERWISE STATED:	
LINEAR FABRICATION	HARNESSES
0-50mm ± 0.5	0-500mm ± 10
50-1000mm ± 1.0	500-1000mm ± 15
1000-2000mm ± 1.5	1000-5000mm ± 20
2000+mm ± 2.0	5000-10000mm ± 30
	10000-15000mm ± 40
	15000-20000mm ± 50

REV	CHG	DETAILS	28.03.2023	GP	--
CUSTOMER	BW	DATE	DRN	CHRD	
BW ENGINEER	GP	PN		REV	C
MATERIAL		DESC	ICB1500 WIRING DIAGRAM		
FINISH		DRG REF			
COLOR		SHEET	1	CP	1
SCALE					A3

NOTE: CABLES MARKED
IN GREEN
ARE SUPPLIED WITH LVD50
& MAY NEED
TO BE EXTENDED
& LUGS ADDED TO MATCH
CONNECTION POINT

LVD TO BE SET AT 10.5V

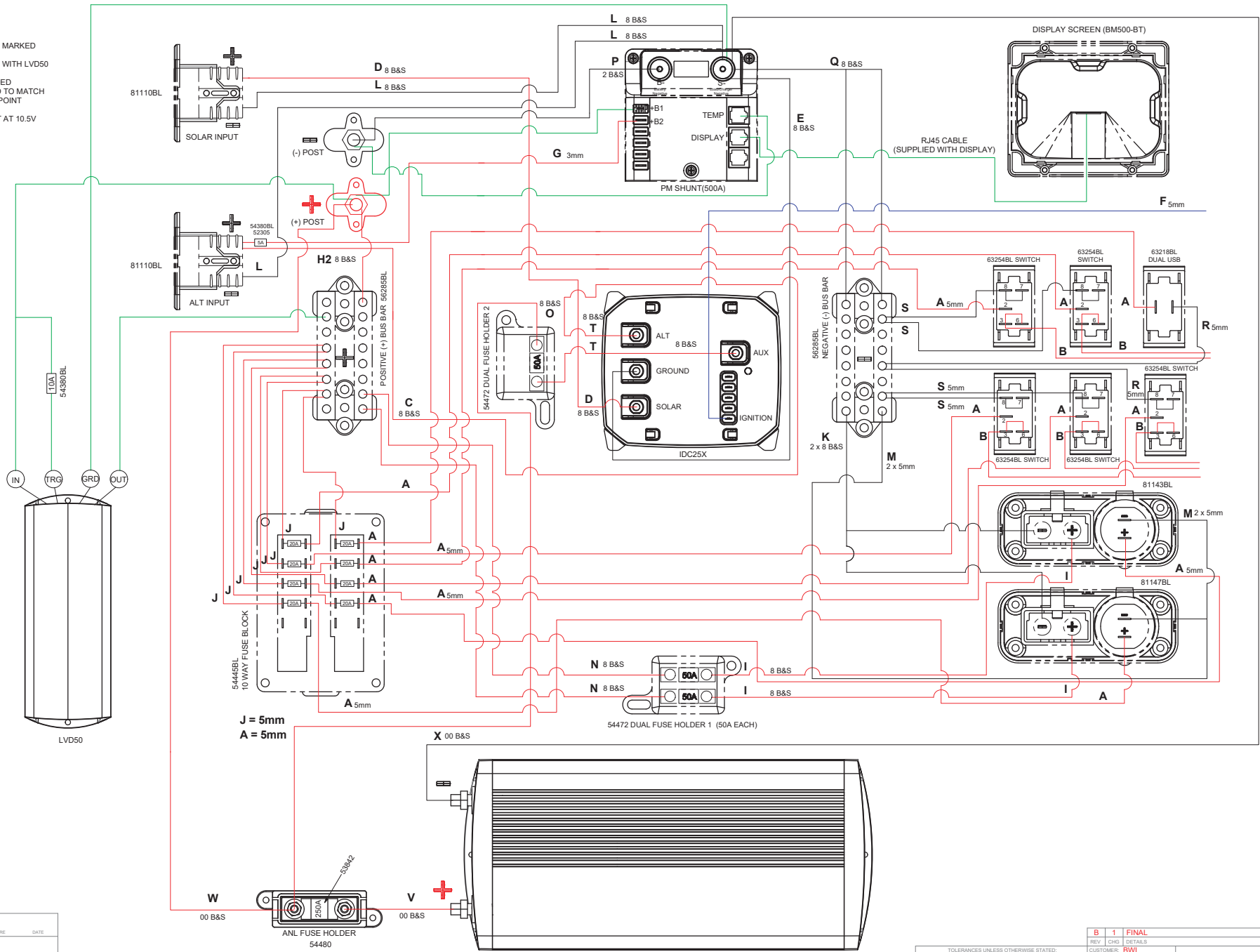

A = 5mm
B = 5mm
S = 5mm

APPROVAL		
SIGNATURE	DATE	
CUSTOMER		
PRODUCT MANAGER		

DIMENSION UNITS = mm
THIRD ANGLE PROJECTION
Brown & Watson International Pty Ltd
1500 Fernside Gully Road
Knoxfield VIC
3180
Australia
ABN 29 004 250 748

TOLERANCES UNLESS OTHERWISE STATED:	
LINEAR FABRICATION	HARNESSES
0-25mm	± 0.2
25-100mm	± 1.0
100-200mm	± 1.5
200+mm	± 2.0
± 0.2	± 10
± 0.5	± 15
± 1.0	± 20
± 1.5	± 30
± 2.0	± 40
± 2.5	± 50

REV	CHG	DETAILS	DATE	DRN	CHRD
B	1	FINAL	28.03.2023	GP	--
CUSTOMER: BWI		PNo:		REV C	
ENGINEER: GP		DESC:		ICB2000 WIRING DIAGRAM	
MATERIAL:		DRG REF:		SHEET 1	
FINISH:		DATE:		OF 1	
COLOUR:		SCALE:		A3	

DO NOT SCALE DRAWING

NOTE: CABLES MARKED IN GREEN ARE SUPPLIED WITH LVD50 & MAY NEED TO BE EXTENDED & LUGS ADDED TO MATCH CONNECTION POINT
LVD TO BE SET AT 10.5V

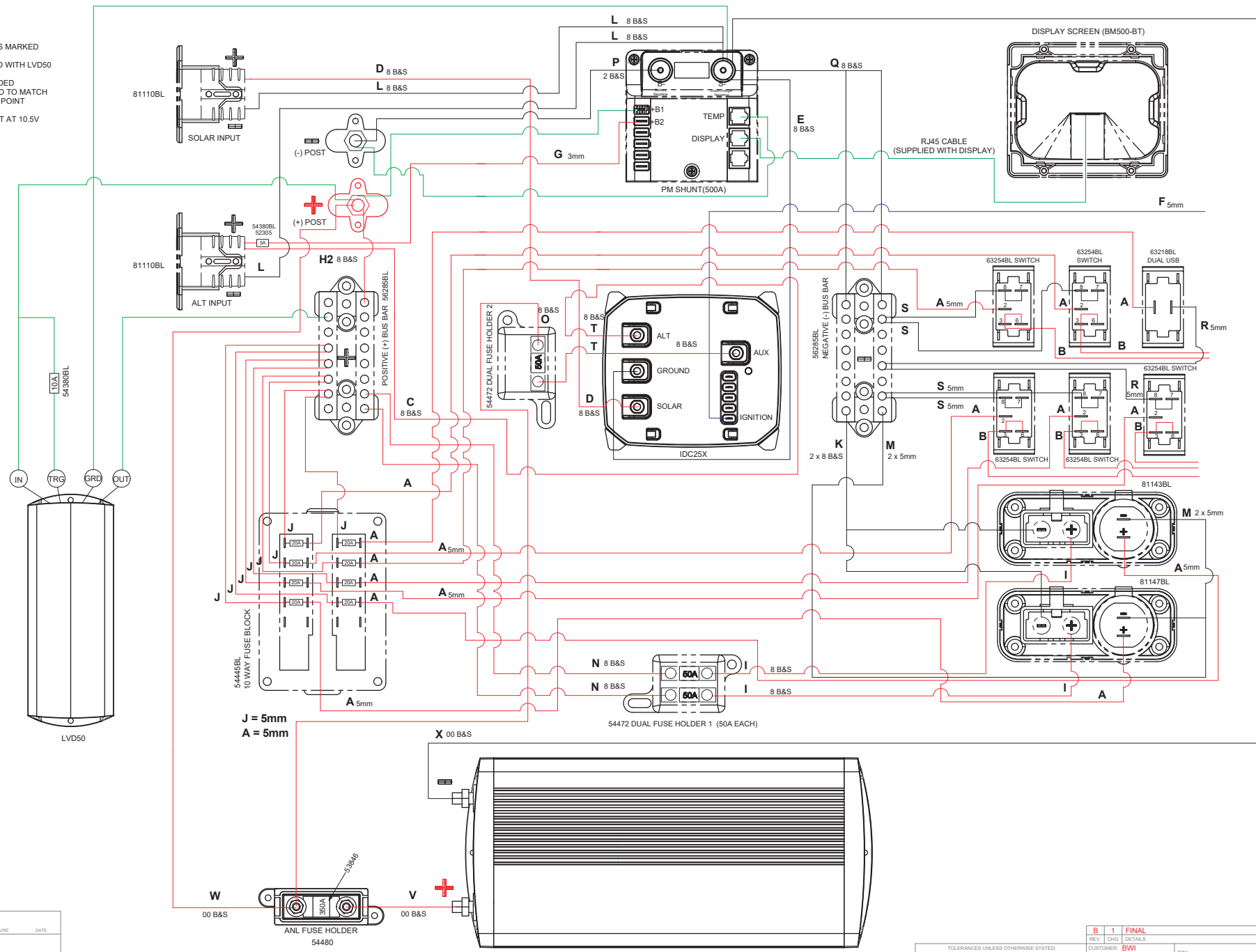

A = 5mm
B = 5mm
S = 5mm

J = 5mm
A = 5mm

APPROVAL	
SIGNATURE	DATE
CUSTOMER	
PRODUCT MANAGER	

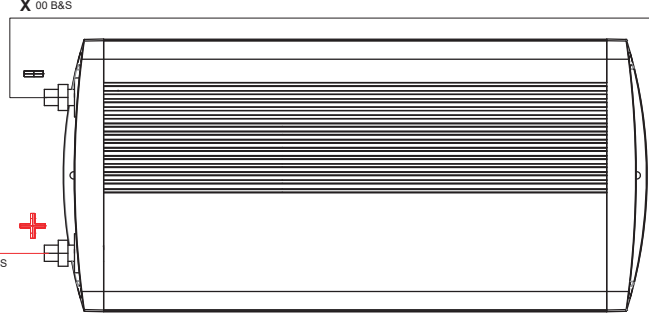
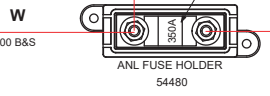

DO NOT SCALE DRAWING

DIMENSION UNITS = mm
Brown & Watson International Pty Ltd
1500 Ferntree Gully Road
Knoxfield VIC
3180
Australia
MBN 29 004 250 748

TOLERANCES UNLESS OTHERWISE STATED:		REVISIONS		CUSTOMER: BVI		PNo		REV		DATE		DRN		CHKD	
LINEAR FABRICATION		FINISHES		MATERIAL:		DESC		SCALE:		SHEET		1		GP	
0-50mm	± 0.5	0-50mm	± 10	ICB3000 WIRING DIAGRAM		DRG REF		1		GP		1		A3	
50-100mm	± 1.0	100-500mm	± 20	SCALE:		1		GP		1		A3			
1000-2000mm	± 1.5	1000-5000mm	± 30												
2000+mm	± 2.0	10000-100000mm	± 40												
		15000-20000mm	± 50												

WARRANTY STATEMENT

Applicable only to product sold in Australia

Brown & Watson International Pty Ltd of 1500 Ferntree Gully Road, Knoxfield, Vic., telephone (03) 9730 6000, fax (03) 9730 6050, warrants that all products described in its current catalogue (save and except for all bulbs and lenses whether made of glass or some other substance) will under normal use and service be free of failures in material and workmanship for a period of five (5) years (unless this period has been extended as indicated elsewhere) from the date of the original purchase by the consumer as marked on the invoice. This warranty does not cover ordinary wear and tear, abuse, alteration of products or damage caused by the consumer. Projecta solar panels are covered by a 1 year warranty for materials and workmanship and a 20 year warranty for at least 80% power output.

To make a warranty claim the consumer must deliver the product at their cost to the original place of purchase or to any other place which may be nominated by either BWI or the retailer from where the product was bought in order that a warranty assessment may be performed. The consumer must also deliver the original invoice evidencing the date and place of purchase together with an explanation in writing as to the nature of the claim.

In the event that the claim is determined to be for a minor failure of the product then BWI reserves the right to repair or replace it at its discretion. In the event that a major failure is determined the consumer will be entitled to a replacement or a refund as well as compensation for any other reasonably foreseeable loss or damage.

This warranty is in addition to any other rights or remedies that the consumer may have under State or Federal legislation.

IMPORTANT NOTE

Our goods come with guarantees that cannot be excluded under the Australian Consumer Law. You are entitled to a replacement or refund for a major failure and compensation for any other reasonably foreseeable loss or damage. You are also entitled to have the goods repaired or replaced if the goods fail to be of acceptable quality and the failure does not amount to a major failure.

Distributed by

AUSTRALIA

Brown & Watson International Pty. Ltd.

Knoxfield Victoria 3180

Phone: (03) 9730 6000

Fax: (03) 9730 6050

National Toll Free: 1800 113 443

NEW ZEALAND OFFICE

Griffiths Equipment Ltd.

19 Bell Avenue,

Mount Wellington,

Auckland 1060, New Zealand

Phone: (09) 525 4575

ISS45

Issue 1: 06.06.23